

Jazzy 1101/1121

Owner's Manual

ATTENTION:
Please read the content
of your owner's manual
before operating your
power chair.



"Jazzy 1121"

How a Power Chair Should Feel!™

Pride
Mobility Products Corp.

Exeter, PA
St. Catharines, ON

1-800-800-8586

www.pridemobility.com

SAFETY GUIDELINES

Please read and follow all instructions in this owner's manual before attempting to operate your power chair for the first time. If there is anything in this manual you do not understand, or if you require additional assistance for set-up, contact your authorized Pride Provider.

Using your Pride product safely depends upon your diligence in following the warnings, cautions, and instructions in this owner's manual. Using your Pride product safely also depends upon your own good judgement and/or common sense, as well as that of your Provider, caregiver, and/or healthcare professional. Pride is not responsible for injuries and/or damage resulting from any person's failure to follow the warnings, cautions, and instructions in this owner's manual. Pride is not responsible for injuries and/or damage resulting from any person's failure to exercise good judgement and/or common sense.

The symbols below are used throughout this owner's manual to identify warnings and cautions. It is very important for you to read and understand them completely.



WARNING! Failure to heed the warnings in this owner's manual may result in personal injury.



CAUTION! Failure to heed the cautions in this owner's manual may result in damage to your power chair.

C O N T E N T S

| | |
|------------------------------------------|----|
| I. INTRODUCTION | 4 |
| II. SAFETY | 6 |
| III. EMI/RFI | 13 |
| IV. THE JAZZY 1101/1121 | 15 |
| V. ASSEMBLY | 20 |
| VI. COMFORT ADJUSTMENTS | 21 |
| VII. BATTERIES AND CHARGING | 28 |
| VIII. OPERATION | 32 |
| IX. CARE AND MAINTENANCE | 47 |
| X. OPTIONAL ACCESSORIES | 52 |
| XI. WARRANTY | 53 |

I. INTRODUCTION

INTRODUCTION

Welcome to Pride Mobility Products Corporation (Pride). Congratulations on the purchase of your new Pride Power Chair. The Pride Power Chair design combines the most advanced state-of-the-art components with modern, attractive styling. We are certain that the design features and trouble-free operation of your new power chair will add convenience to your daily living.

At Pride, your safety is important to us. Please read and follow all of the instructions in this manual before you attempt to operate your power chair for the first time. These instructions were produced for your benefit. Your understanding of these instructions is essential for the safe operation of your new power chair.

Pride is not liable for damage to property or personal injury arising out of unsafe use of a power chair. Pride is also not liable for any property damage or personal injury arising out of the failure of any person and/or user to following the instructions and recommendations set forth in this manual or any other instructions or recommendations contained in other power chair related literature issued by Pride or contained on the power chair itself.

This owner's manual is compiled from the latest specifications and product information available at the time of publication. We reserve the right to make changes as they become necessary. Any changes to our products may cause slight variations between the illustrations and explanations in this manual and the product you have purchased.

If you experience any problems with your power chair that you are unable to solve, or if you do not feel capable of safely following any of the instructions and/or recommendations as contained in this manual, please contact your authorized Pride Provider for assistance.

Once you understand how to operate and take care of your power chair, we are certain that it will give you years of trouble-free service and enjoyment.

Information Exchange

We want to hear your questions, comments, and suggestions about this manual. We would also like to hear about the safety and reliability of your new power chair, and about the service you received from your authorized Pride Provider.

Please notify us of any change of address, so we can keep you apprised of important information about safety, new products, and new options that can increase your ability to use and enjoy your power chair. Please feel free to contact us at the address below:

Pride Mobility Products Corporation
Attn: Customer Care Department
182 Susquehanna Avenue
Exeter, PA 18643-2694
customer@pridemobility.com
800-424-8205

I. INTRODUCTION

Pride Owners Club

As an owner of a Pride product, you are invited to register your product's warranty and enroll in the Pride Owners Club. You may do so by filling out and returning your enclosed registration card or by visiting Pride's web site at www.pridemobility.com. As a registered member, each time you visit our site, you will have access to the most interactive and honest educational venue available today for people with mobility needs, their families, and friends.

From our home page, select "Owners Club" to enter a page dedicated to current and potential Pride product owners. You will gain access to interviews, stories, recreation ideas, daily living tips, product and funding information, and interactive message boards. These message boards invited you to communicate with other Pride customers as well as Pride representatives who are available to assist you with any questions or concerns you may have.

My Authorized Pride Provider Is:

Name: _____

Address: _____

Phone Number: _____

Purchase Date: _____

NOTE: If you ever lose or misplace your product registration card or your copy of this manual, contact us and we will be glad to send you a new one immediately.

II. SAFETY

SAFETY



WARNING! Do not operate your new power chair for the first time without completely reading and understanding this owner's manual.

Your power chair is a state-of-the-art life-enhancement device designed to increase mobility. Pride provides an extensive variety of products to best fit the individual needs of the power chair user. Please be aware that the final selection and purchasing decision regarding the type of power chair to be used is the responsibility of the power chair user, who is capable of making such a decision, and his/her healthcare professional (i.e., medical doctor, physical therapist, etc.).

The contents of this manual are based on the expectation that a mobility device expert has properly fitted the power chair to the user and has assisted the prescribing healthcare professional and/or the authorized Pride Provider in the instruction process for the use of the product.

There are certain situations, including some medical conditions, where the power chair user will need to practice operating the power chair in the presence of a trained attendant. A trained attendant can be defined as a family member or care professional specially trained in assisting a power chair user in various daily living activities.

As you begin using your power chair during daily activities, you will probably encounter situations in which you will need some practice. Simply take your time and you will soon be in full and confident control as you maneuver through doorways, on and off of elevators, up and down ramps, and over moderate terrain.

Below are some precautions, tips, and other safety considerations that will help the user become accustomed to operating the power chair safely.

Modifications

Pride has designed and engineered your power chair to provide maximum mobility and utility. A wide range of accessories is available from your authorized Pride Provider to further customize your power chair to better suit your needs and/or preferences. However, under no circumstances should you modify, add, remove, or disable any feature, part, or function of your power chair.



WARNING! Do not modify your power chair in any way not authorized by Pride. Unauthorized modifications may result in personal injury and/or damage to your power chair.

Pre-Ride Safety Check

Get to know the feel of your power chair and its capabilities. Pride recommends that you perform a safety check before each use to make sure your power chair operates smoothly and safely. See IX. "Care and Maintenance."

Perform the following inspections prior to using your power chair:

- Check for proper tire inflation. Maintain **30-35 psi** in each tire (if equipped with pneumatic tires).
- Check all electrical connections. Make sure they are tight and not corroded.
- Check all controller connections to the electronics tray. Make sure they are secured properly.
- Check the brakes. See IX. "Care and Maintenance."
- Check battery charge. See VII. "Batteries and Charging."

II. SAFETY

NOTE: If you discover a problem, contact your authorized Pride Provider for assistance.

Weight Limitations

Your power chair is rated for a maximum weight capacity. Please refer to the specifications table for this limit.



WARNING! Exceeding the weight capacity voids your warranty and may result in personal injury and/or damage to your power chair. Pride will not be held responsible for injuries and/or property damage resulting from failure to observe weight limitations.

WARNING! Do not carry passengers on your power chair. Carrying passengers on your power chair may result in personal injury and/or property damage.

Tire Inflation

If your power chair is equipped with pneumatic tires, you should check or have the air pressure checked at least once a week. Proper inflation pressures will prolong the life of your tires and help ensure the smooth operation of your power chair.



WARNING! It is important that 30-35 psi tire pressure be maintained in pneumatic tires at all times. Do not underinflate or overinflate your tires. Low pressure may result in loss of control, and overinflated tires may burst. Failure to maintain 30-35 psi tire pressure in pneumatic tires at all times may result in tire and/or wheel failure, causing serious personal injury and/or damage to your Jazzy.

WARNING! Inflate your power chair drive tires from a regulated air source with an available pressure gauge. Inflating your tires from an unregulated air source could overinflate them, resulting in a burst tire and/or personal injury.

Incline Information

More and more buildings have ramps with specified degrees of inclination, designed for easy and safe access. Some ramps may have turning switchbacks (180-degree turns) that require you to have good cornering skills on your power chair.

- Proceed with extreme caution as you approach the downgrade of a ramp or other incline.
- Take wide swings with your power chair's front wheels around any tight corners. If you do that, the power chair's rear wheels will follow a wide arc, not cut the corner short, and not bump into or get hung up on any railing corners.
- When driving down a ramp, keep the power chair's speed adjustment set to the slowest speed setting to ensure a safely controlled descent. See VIII. "Operation."
- Avoid sudden stops and starts.

When climbing an incline, try to keep your power chair moving. If you must stop, start up again slowly and then accelerate cautiously. When driving down an incline, set your power chair to the slowest setting and drive in the forward direction only. If your power chair starts to move down the incline faster than you anticipated or desired, allow it to come to a complete stop by releasing the joystick, then push the joystick forward slightly to ensure a safely controlled descent.

II. SAFETY

WARNING! When climbing an incline, do not zigzag or drive at an angle up the face of the incline. Drive your power chair straight up the incline. This greatly reduces the possibility of a tip or a fall. Always exercise extreme caution when negotiating an incline.



WARNING! You should not travel up or down a potentially hazardous incline (i.e., areas covered with snow, ice, cut grass, or wet leaves).

WARNING! When on any sort of an incline or decline, never place the power chair in freewheel mode while seated on it or standing next to it. Doing so may result in personal injury and/or damage to your power chair.

WARNING! Never travel down an incline backwards. This may result in personal injury.

WARNING! Even though your power chair is capable of climbing slopes greater than those illustrated in figure 1, do not, under any circumstances, exceed the incline guidelines or any other specifications presented in this manual. Doing so could cause instability in your power chair, resulting in personal injury and/or damage to your power chair.

In compliance with the Americans with Disabilities Act of 1990, all handicap public access ramps are required to have a maximum slope of 5°. Therefore, Pride recommends that the maximum slope of an incline you attempt to safely ascend or descend on your power chair does not exceed 5°. See figure 1.



WARNING! Any attempt to climb or descend a slope steeper than 5° may put your power chair in an unstable position and cause it to tip, resulting in personal injury.

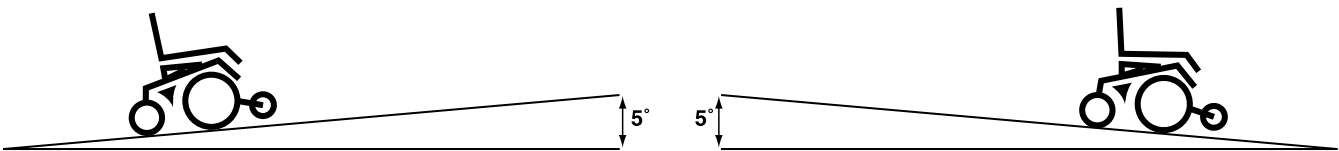

Figure 1. Maximum Safe Angle (Ascending and Descending)

Braking Information

Your power chair is equipped with two powerful brake systems:

1. Regenerative — uses electricity to rapidly slow the vehicle when the joystick returns to the center/stop position.
2. Disc Park Brake — activates mechanically after regenerative braking slows the vehicle to near stop, or when power is removed from the system for any reason.

Cornering Information

While your power chair is equipped with rear caster wheels in back and anti-tip wheels in front, excessively high cornering speeds can still create the possibility of tipping. Factors which affect the possibility of tipping include, but are not limited to: cornering speed, steering angle (how sharply you are turning), uneven road surfaces, inclined road surfaces, riding from an area of low traction to an area of high traction (such as passing from a grassy area to a paved area – especially at high speed while turning), and abrupt directional changes. High cornering speeds are not recommended. If you feel that you may tip over in a corner, reduce your speed and steering angle (i.e., lessen the sharpness of the turn) to prevent your power chair from tipping.



WARNING! When cornering sharply, reduce your speed. This greatly reduces the possibility of a tip or fall. To avoid personal injury and/or property damage, always exercise common sense when cornering.

II. SAFETY

Outdoor Driving Surfaces

Your power chair is designed to provide optimum stability under normal driving conditions—dry, level surfaces composed of concrete, blacktop, or asphalt. However, Pride recognizes that there will be times when you will encounter other surface types. For this reason, your power chair is designed to perform admirably on packed soil, grass, and gravel. Feel free to use your power chair safely on lawns and in park areas.

- Reduce your power chair's speed when driving on uneven terrain and/or soft surfaces.
- Avoid tall grass that can entangle the running gear.
- Avoid loosely packed gravel and sand.
- If you feel unsure about a driving surface, avoid that surface.

Freewheel Mode

Your power chair is equipped with a manual freewheel system to allow for manual maneuverability by a trained attendant. For more information about how to place your power chair into and out of freewheel mode, see IV. "The Jazzy 1101/1121."

WARNING! Do not use your power chair in freewheel mode without an attendant present. Personal injury may result.



WARNING! Do not attempt to personally place your power chair in freewheel mode while seated on it. Personal injury may result. Ask an attendant for assistance if necessary.

WARNING! Do not place your power chair in freewheel mode while on an incline. The chair could roll uncontrollably on its own, causing personal injury.

Stationary Obstacles (Steps, Curbs, etc.)

Proceed with extreme caution when driving near raised surfaces, unprotected ledges and/or drop-offs (curbs, porches, stairs, etc.). The correct method for approaching a curb is illustrated in figure 1a.

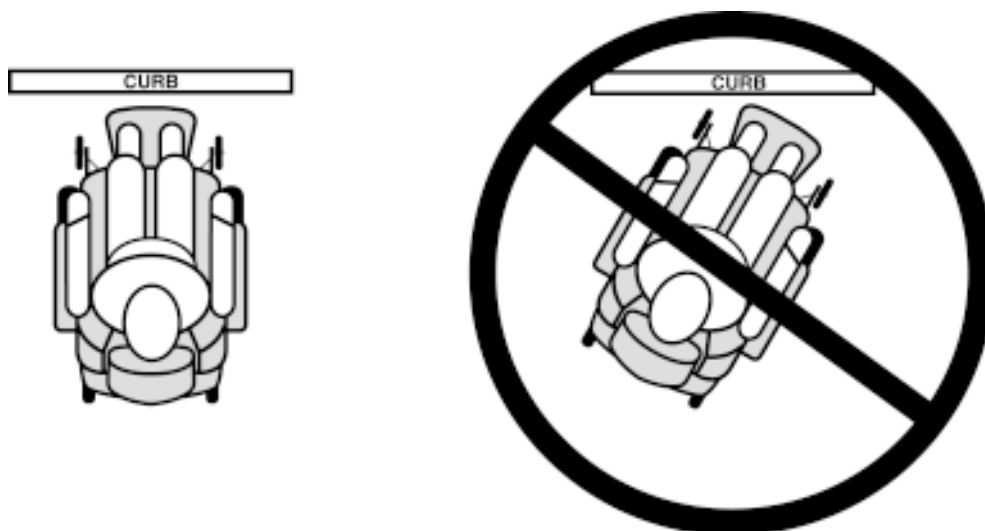

Figure 1a. Curb Approach (Correct and Incorrect)

II. SAFETY



WARNING! Do not attempt to have your power chair climb or descend an obstacle that is higher than two inches unless you have the assistance of an attendant.

WARNING! Do not attempt to have your power chair proceed backward down any step, curb, or other obstacle. This may cause the power chair to tip and cause personal injury.

Public Streets and Roadways



WARNING! You should not operate your power chair on public streets and roadways. Be aware that it may be difficult for traffic to see you when you are seated on your power chair. Obey all local pedestrian traffic rules. Wait until your path is clear of traffic, and then proceed with extreme caution.

Stairs and Escalators

Power chairs are not designed to travel up or down stairs or escalators. Always use an elevator.



WARNING! Never use your power chair to negotiate steps or escalators. You may cause injury to yourself and to others and/or damage your power chair.

Doors

- Determine if the door opens toward or away from you.
- Drive your power chair gently and slowly forward to push the door open. Or drive your power chair gently and slowly backward to pull the door open.

Elevators

Modern elevators have a door edge safety mechanism that, when pushed, reopens the elevator door(s).

- If you are in the doorway of an elevator when the door(s) begin to close, push on the rubber door edge or allow the rubber door edge to contact the power chair and the door will reopen.
- Use care that pocketbooks, packages, or power chair accessories do not become caught in elevator doors.

EMI & RFI

Laboratory tests performed by the Food and Drug Administration (FDA) have shown that radio waves can cause unintended motion of electric mobility vehicles. Radio waves are a form of electromagnetic energy (EM). When EM adversely affects the operation of an electronic device, it is called Electromagnetic Interference (EMI) or Radio Frequency Interference (RFI). For more information, see III. "EMI/RFI."

Lift/Elevation Products

If you will be traveling with your power chair, you may find it necessary to use a lift/elevation product to aid in transportation. Pride recommends that you closely review the instructions, specifications, and safety information set forth by the manufacturer of the lift/elevation product before using that product.

Motor Vehicle Transport

Currently, there are no standards approved for tie-down systems in a moving vehicle of any type to transport a person while seated in a power chair.

Transfers

Transferring onto and off of your power chair requires a good sense of balance. Always have an attendant or healthcare professional present while learning to properly transfer yourself.

II. SAFETY

To eliminate the possibility of injury, Pride recommends that you or a trained attendant perform the following tasks before attempting a transfer:

- Turn the power off. See VIII. “Operation.”
- Ensure your power chair is not in freewheel mode. See IV. “The Jazzy1101/1121.”
- Turn both caster wheels toward the transfer destination to improve power chair stability during transfer.
- Make sure both armrests are flipped up or removed from your power chair.
- Flip the footrest up, or move the leg rests aside; this will help to keep your feet from getting caught on the footrest or the leg rests during the transfer.
- Reduce the distance between your power chair and the object you are transferring onto.



WARNING! Before transferring, position yourself as far back as possible in the power chair seat to prevent the power chair from tipping forward during transfer and causing injury.

WARNING! Avoid using your armrests for weight bearing purposes. Such use may cause the power chair to tip and cause personal injury.

WARNING! Avoid putting all of your weight on the footrest. Such use may cause the power chair to tip and cause personal injury.

Positioning Belts

Your authorized Pride Provider, therapist(s), and other healthcare professionals are responsible for determining your requirement for a positioning belt in order to operate your power chair safely.



WARNING! If you require a positioning belt to safely operate your power chair, make sure it is fastened securely. Serious personal injury may result if you fall from the power chair.

WARNING! The positioning belt is not designed for use as a seat belt in a motor vehicle. Nor is your Jazzy suitable for use as a seat in any vehicle. Anyone traveling in a vehicle should be properly belted into seats approved by the vehicle manufacturer.

WARNING! Do not sit on your power chair while it is in a moving vehicle. Personal injury and/or property damage may result.

WARNING! Always be sure your power chair and its batteries are properly secured when it is being transported. Failure to do so may result in personal injury and/or damage to your power chair.

Inclement Weather Precautions



WARNING! Pride recommends that you do not operate your power chair in icy or slippery conditions or on salted surfaces (i.e., walks or roads). Such use may adversely affect the performance and safety of your power chair, resulting in an accident and personal injury.

WARNING! Do not expose your power chair to any type of moisture at any time (rain, snow, mist, or wash). Such exposure can damage your power chair. Never operate your power chair if it has been exposed to moisture until it has dried thoroughly.

II. SAFETY

Reaching and Bending

Never reach, lean, or bend while driving your power chair. If it is absolutely necessary to reach, lean, or bend while seated on your power chair, it is important to maintain a stable center of gravity and keep the power chair from tipping. Pride recommends that the power chair user determine his/her personal limitations and practice bending and reaching in the presence of a qualified healthcare professional.



WARNING! Do not bend, lean, or reach for objects if you have to pick them up from the floor by reaching down between your knees. Movements such as these may change your center of gravity and the weight distribution of the power chair. This may cause your power chair to tip, possibly resulting in personal injury. Keep your hands away from the tires when driving.

Batteries

In addition to following the warnings below, be sure to comply with all other battery handling information. For more information about your power chair's batteries, see VII. "Batteries and Charging."



WARNING! Power chair batteries are heavy. See specifications table. If you are unable to lift that much weight, be sure to get help. Lifting beyond your capacity can result in personal injury.

WARNING! Battery posts, terminals, and related accessories contain lead and lead compounds. Wash hands after handling.

WARNING! Always protect the batteries from freezing and never charge a frozen battery. Charging a frozen battery may result in personal injury and/or damage to the battery.

Preventing Unintended Movement



WARNING! If you anticipate being seated in a stationary position for an extended period of time, turn off the power. This will prevent unexpected motion from inadvertent joystick contact. This will also eliminate the possibility of unintended chair movement from electromagnetic (EM) sources. Failure to do so may result in personal injury.

Prescription Drugs/Physical Limitations

Users must exercise care and common sense when operating a power chair. This includes awareness of safety issues when taking prescribed or over-the-counter drugs or when the user has specific physical limitations.



WARNING! Consult your physician if you are taking prescribed or over-the-counter medication or if you have certain physical limitations. Some medications and limitations may impair your ability to operate your power chair in a safe manner.

Alcohol

The power chair user must exercise care and common sense when operating his/her power chair. This includes awareness of safety issues while under the influence of alcohol.



WARNING! Do not operate your power chair while you are under the influence of alcohol, as this may impair your ability to operate your power chair in a safe manner.

Removable Parts



WARNING! Do not attempt to lift or move a power chair by any of its removable parts. Personal injury and/or damage to the power chair may result.

III. EMI / RFI

EMI/RFI

Laboratory tests performed by the Food and Drug Administration (FDA) have shown that radio waves can cause unintended motion of power chairs. Radio waves are a form of electromagnetic energy. When this energy adversely affects the operation of an electronic device, it is called Electromagnetic Interference (EMI) or Radio Frequency Interference (RFI).



WARNING! Radio waves may interfere with the control of power chairs.

Frequently Asked Questions (FAQs)

The following FAQs summarize what you should know about EMI/RFI. Use this information to minimize the risk that EMI/RFI will affect your power chair.

Where do radio waves come from?

Radio waves are emitted from the antennas of cellular phones, mobile two-way radios (such as walkie-talkies), radio stations, TV stations, amateur radio (HAM) transmitters, wireless computer links, microwave sources, and paging transmitters. Radio waves are a form of electromagnetic energy (EM). Because electromagnetic energy is more intense closer to the transmitting antenna (source of emission), the EM fields from two-way radios are of special concern to power chair users.

If my power chair is affected by EMI/RFI, what kind of motion should I expect?

This is hard to predict. It would depend on a number of factors:

- Strength of the radio waves
- Construction of the power chair
- Position of the power chair (whether it is on level ground or on an incline)
- Whether or not the power chair is in motion

An affected power chair's movement can be erratic. It may move by itself or come to a sudden stop. Furthermore, it is possible for EMI/RFI to unexpectedly release the brakes on a power chair. Some intense sources of EMI/RFI can even damage the control system of the power chair.

Is there any way to know for sure whether radio waves are responsible for the unintended motion of my power chair?

Unfortunately, interference from radio wave sources may be difficult to recognize, since the signals from these sources are invisible and may be intermittent. However, the FDA recommends that you report all incidents of unintended motion or brake release to the power chair manufacturer and, if possible, note whether there was a radio wave source nearby at the time of the incident.

Has anyone been hurt from erratic, unintended motion of power chairs?

The FDA has reports of injuries that resulted from the apparent uncontrolled motion of power chairs. However, it is unclear how many of these incidents were actually caused by radio wave interference.

Are all power chairs susceptible to EMI/RFI?

Each make and model of chair differs in its ability to resist electromagnetic interference. That is, each has a particular level of "immunity" to interference, measured in volts per meter (V/m). A higher immunity level offers greater protection. In other words, a power chair with a high immunity level is less likely to be affected by a strong radio source than one with a low immunity level.

III. EMI/RFI

What is the FDA doing about the problem?

The FDA has written to the manufacturers of power chairs and requested that they test their new products to be sure that they provide a reasonable degree of immunity against EMI/RFI. The letter states that power chairs should have an immunity of at least 20 V/m. This provides a reasonable degree of protection against the common sources of EMI/RFI.

The FDA has also requested that these manufacturers clearly label their products with the immunity level, or state that the immunity level is not known. The labeling and informational material supplied with the power chair must explain what the immunity level means, and the labeling or informational material must warn users about the possibility of EMI/RFI and how to avoid it. In addition, the FDA has recommended that manufacturers establish an educational program to inform users of power chairs, and their caregivers, about the problems associated with EMI/RFI, and the actions they can take to minimize the risk.

What can I do to find out if my power chair is likely to be affected by EMI/RFI?

If you've had your power chair for a long time and haven't experienced any unintended motion, it is not likely that you will have problems in the future. But it is always possible that problems could arise if you are close to a source of radio waves. Therefore, it is very important to be alert to this possibility. The Jazzy meets or exceeds an immunity level of at least 20 V/m.

What can I do to reduce the risk that my power chair could be affected by EMI/RFI?

Here are some precautions you can take:

- Do not turn on or use hand-held personal communications devices, such as citizens band (CB) radios and cellular phones, while the power chair is on.
- Be aware of nearby transmitters, such as radio or TV stations and hand-held or mobile two-way radios, and try not to come close to them. For example, if you are in a power chair with an immunity level of 20 V/m, you should remain at least three feet from a hand-held two-way radio and ten feet from a mobile two-way radio.
- Be aware that adding accessories and/or components, or modifying the power chair may make it more susceptible to interference from radio wave sources. There is no easy way to evaluate their effect upon the overall immunity of the power chair.

What should I do if my power chair moves unexpectedly?

If unintended motion or brake release occurs, turn the power chair off as soon as it is safe to do so. Call Pride at 800-424-8205 to report the incident.

IV. THE JAZZY 1101/1121

THE JAZZY 1101/1121

The Jazzy has two main assemblies: the seat and the power base. See figures 2 and 3. Typically, the seat assembly includes the armrests, seatback, and seat base. The Jazzy seat may also have some optional accessories attached to it, such as a rear basket, a cane and crutch holder, or a cup holder. See X. "Optional Accessories."

The power base is the heart of the Jazzy. The power base assembly includes two motor/brake assemblies, two drive wheels, two anti-tip wheels, two caster wheels, two batteries, and wiring harnesses.

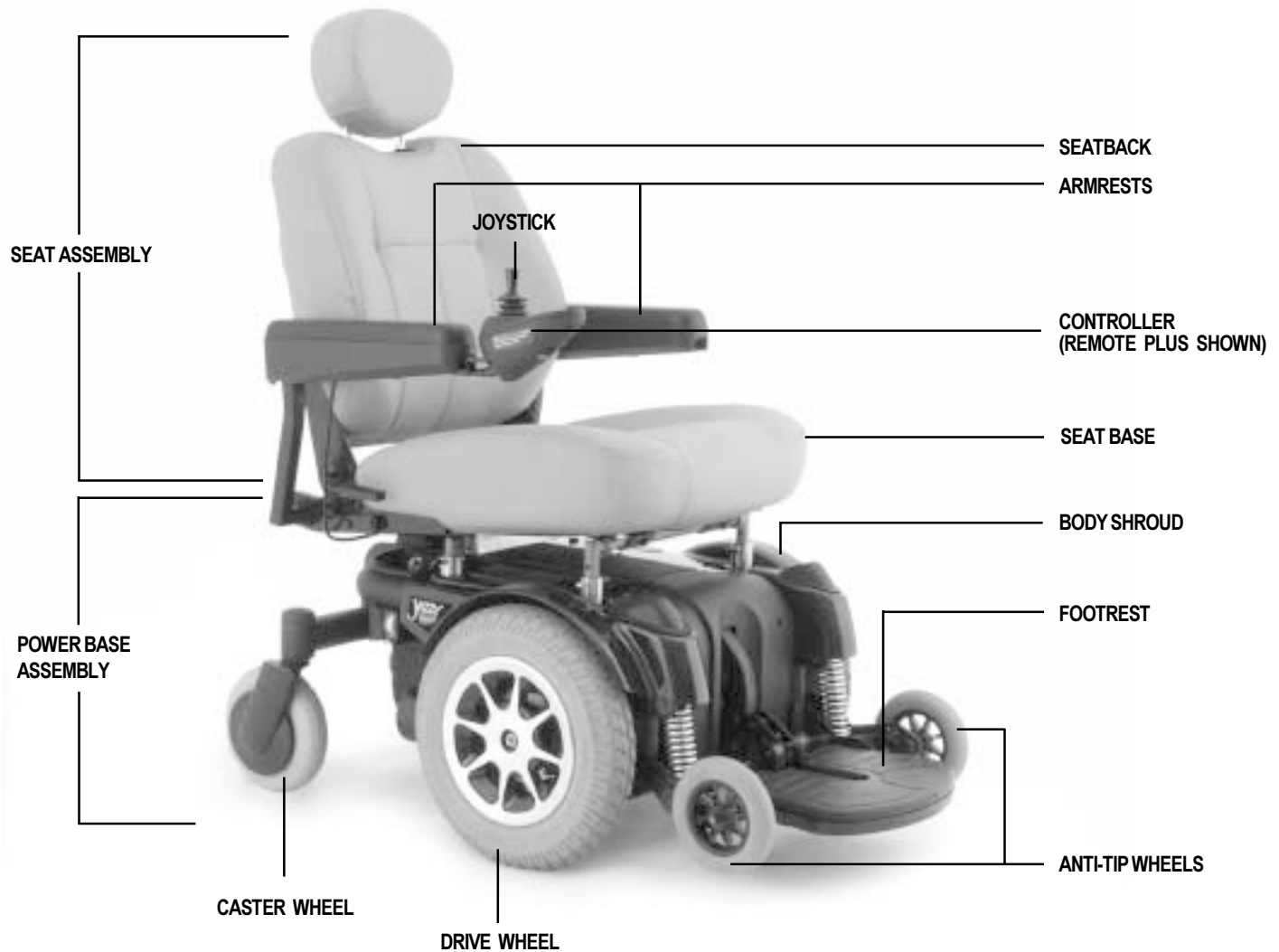

Figure 2. The Jazzy 1121 (1101 is similar.)

IV. THE JAZZY 1101/1121

| SPECIFICATIONS | |
|--------------------|-------------------------------------------------------------------------------------------------------------------------------------------------------------------------------------------------------------------------------------|
| Suspension: | Full suspension (<i>Active-Trac— 1121 only</i>) |
| Drive Wheels: | 14 in., pneumatic, center-mounted (<i>solid tires are optional</i>) |
| Caster Wheels: | 8 in., solid, rear articulating |
| Anti-tip Wheels: | 6 in., solid, front mounted |
| Maximum Speed: | Up to 5 mph (<i>4 mph w/ 1121 HD option</i>)* |
| Brakes: | “Intelligent Braking” electronic regenerative, disc park brake |
| Ground Clearance: | 3.5 in. |
| Turning Radius: | 20.5 in. |
| Overall Size: | Length: 38.5 in. Width: 23.8 in. |
| Seating Options: | Medium-Back Seat (<i>standard</i>) Synergy Seat (<i>optional</i>) Versa Tilt (<i>optional</i>) High-Back Seat (<i>optional</i>) Reclining Seat (<i>optional</i>) Power Elevating (<i>optional</i>) |
| Drivetrain: | Two motor, mid-wheel |
| Batteries: | Two 12-volt, NF-22 batteries |
| Range: | Up to 25 miles* |
| Battery Charger: | 5-amp, onboard (<i>standard</i>) 5-amp, off-board (<i>optional</i>) |
| Electronics: | 50-amp PG VSI Controller (<i>standard</i>) 70-amp PG Pilot (<i>standard w/1121 Heavy Duty option</i>) 70-amp PG Remote Plus Controller (<i>optional</i>) 70-amp Dynamic Europa Remote Controller (<i>optional</i>) |
| Weight Capacity: | 300 lbs. 400 lbs. (<i>w/ 1121 HD option - includes 4 mph motors, 70-amp Pilot, curved caster beam, and solid drive tires</i>) |
| Component Weights: | Base: 135.5 lbs. Medium-Back Seat: 33 lbs. Batteries: 38 lbs. each |
| Warranty: | Lifetime limited warranty on frame Two-year warranty on electronics Eighteen-month warranty on motor/gearbox assembly |

*Varies with user weight and terrain.

IV. THE JAZZY 1101/1121

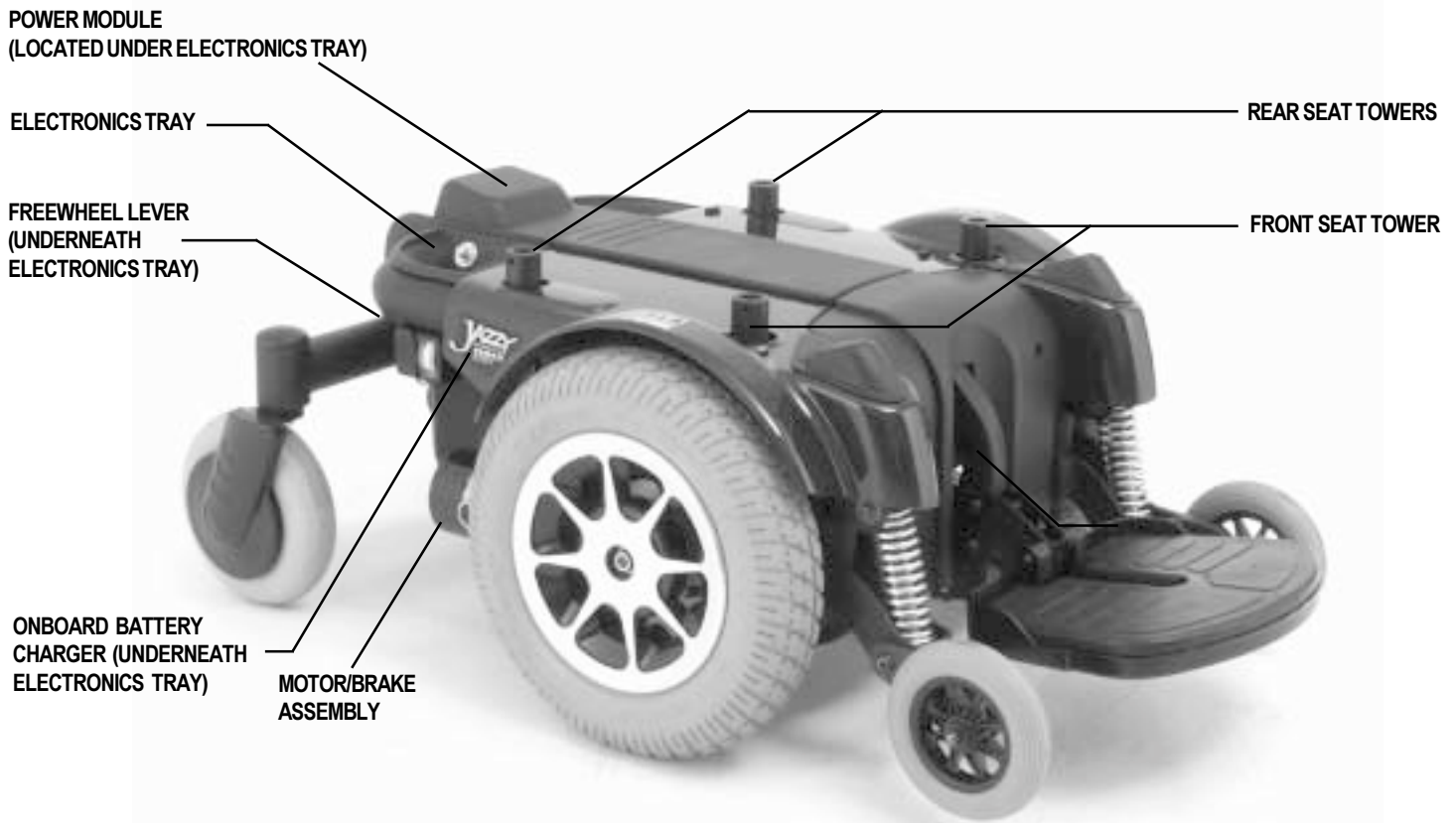

Figure 3. The Jazzy 1121 Power Base (1101 is similar.)

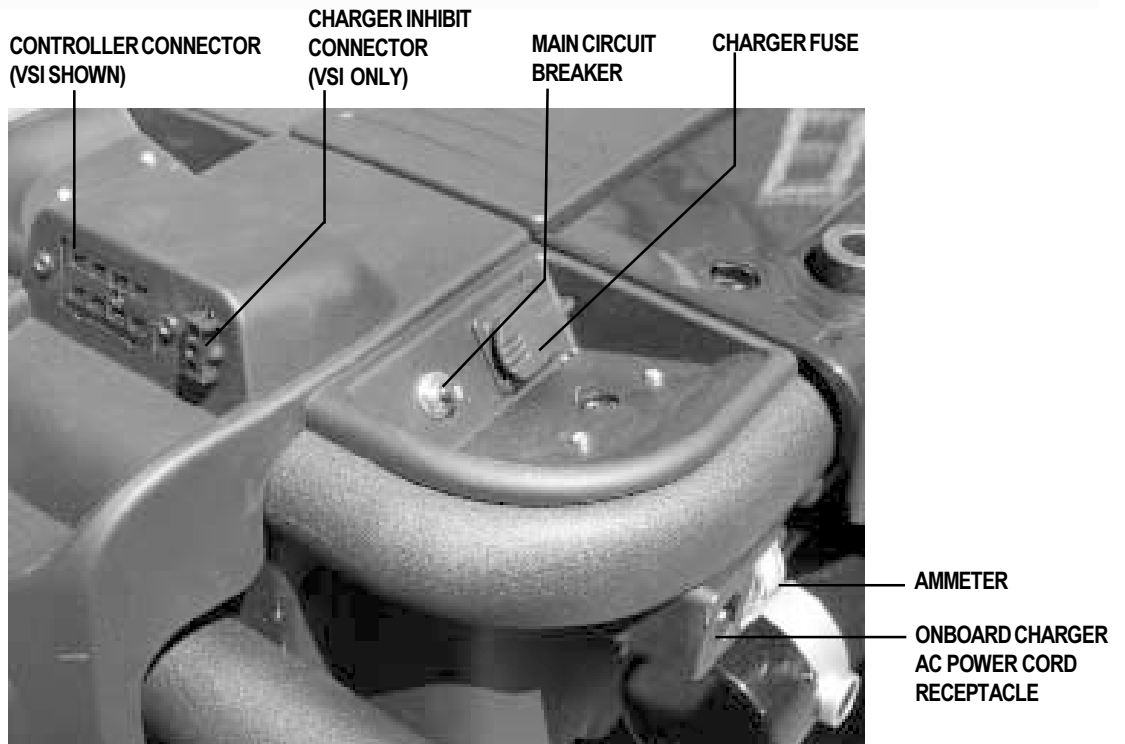

Figure 4. The Jazzy 1101/1121 Electronics Tray

IV. THE JAZZY 1101/1121

Electronics Tray

The electronics tray is located on the back of the power base. See figures 3 and 4. The ammeter, the onboard charger AC power cord, the main circuit breaker, the controller connector, and the charger fuse are all located on the electronics tray.

Ammeter: The ammeter displays the charger's current output in amps. See VII. "Batteries and Charging."

Onboard Charger AC Power Cord Receptacle: This is where the onboard charger AC power cord plugs into the power base.

Main Circuit Breaker: The main circuit breaker is a safety feature built into your Jazzy. When the batteries and the motors are heavily strained (e.g., from excessive loads), the main circuit breaker trips to prevent damage to the motors and the electronics. If the circuit trips, allow your Jazzy to "rest" for approximately one minute. Next, push in the circuit breaker button, turn on the controller, and continue normal operation. If the main circuit breaker continues to trip repeatedly, contact your authorized Pride Provider.

Controller Connector: This is where the controller connects to the power base. The VSI controller uses a large 9-pin connector. The Remote Plus and the Europa use smaller, multi-pin communications cable connectors (not shown).

Charger Inhibit Connector: The VSI controller is equipped with a charger inhibit connector. The charger inhibit enables the onboard charger to disable the controller during charging. The charger inhibit connector is coded with colored dots. The dots are positioned so that you can align the flat side of the male connector with the flat side of the female connector before making the connection.



CAUTION! Failure to properly align the connectors can result in damage to the controller, the charger harness, and the connectors.

Charger Fuse: The charger fuse protects the ammeter from current overload. There are three fuses on the utility tray. The top one is the charger fuse. The bottom two are spares.

Power Actuator Connector and Lighting System Connector (VSI Only): This is where the power actuator connects to the controller. Standard lighting systems have a single-pin connector. Full lighting systems with the VSI controller use a 3-pin connector. Not shown.

Active-Trac Suspension (1121 Only)

The Jazzy 1121 is equipped with Active-Trac Suspension (ATS). ATS is a suspension system designed to make your Jazzy traverse different types of terrain and obstacles while maintaining smooth operation. With ATS, your front anti-tip wheels work in conjunction with your motor suspension to help you maneuver over obstacles in excess of three inches in height.

As your front anti-tip wheels come in contact with an obstacle, the front anti-tip wheel assembly is drawn upward. At the same time, your motors are forced downward. This allows the motors to push the Jazzy 1121 over an obstacle without the possibility of becoming "hung up" on the obstacle.

ATS also helps in day-to-day operating conditions. For instance, when you release the joystick, your Jazzy begins to slow down. As the chair slows down, the front anti-tip wheels will automatically drop toward the ground. This will reduce the forward tip that is typically encountered with center-wheel drive chairs.

IV. THE JAZZY 1101/1121

Manual Freewheel Lever

For your convenience, your Jazzy is equipped with a manual freewheel system. This system consists of one or more freewheel levers which enable you to disengage the drive motors and maneuver the chair manually.



WARNING! Do not use your Jazzy while the drive motors are disengaged unless you are in the presence of an attendant! Do not disengage the drive motors when your Jazzy is on an incline. The chair could roll down on its own, causing injury!



CAUTION! It is important to remember that when your Jazzy is in freewheel mode, the braking system is disengaged.

To operate the single manual freewheel lever:

1. Push the safety latch in and pull up the manual freewheel lever for freewheel mode (drive disengaged). See figure 5.
2. Push the manual freewheel lever down for drive mode (drive engaged). See figure 5a.



Figure 5. Freewheel Mode (Drive Disengaged)

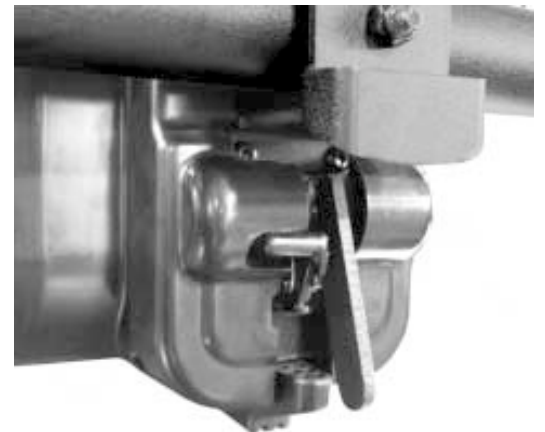

Figure 5a. Drive Mode (Drive Engaged)

To operate the dual manual freewheel levers:

1. Pull up the manual freewheel lever on each motor for freewheel mode (drive disengaged). See figure 6.
2. Push down the manual freewheel lever on each motor down for drive mode (drive engaged). See figure 6a.

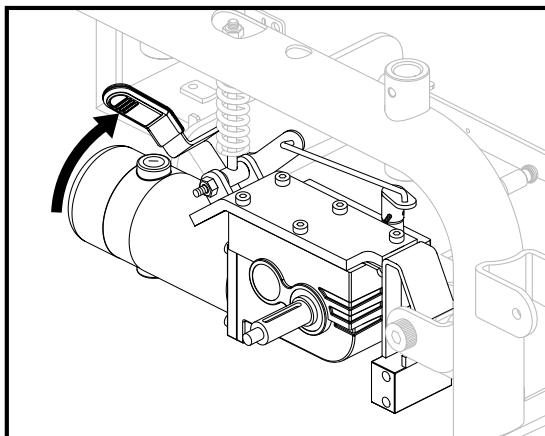

Figure 6. Freewheel Mode (Drive Disengaged)

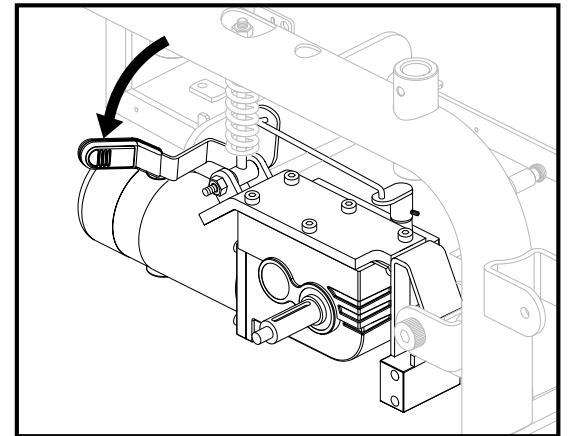

Figure 6a. Drive Mode (Drive Engaged)

NOTE: If the lever is difficult to move in either direction, rock your Jazzy back and forth slightly. The lever should then move to the desired position.

V. ASSEMBLY

SEAT INSTALLATION

The Universal Mounting System (UMS) consists of universal parts that may be used on any medium-back or high-back seat, regardless of seat width or seat depth. The two main components are aluminum extrusions that can be mounted to any medium-back or high-back seat. These extrusions attach to a pair of trapeze bars that are mounted to four steel towers.



WARNING! Do not pick up the seat frame by the armrests. They are free to pivot, and you may lose control of the seat if they do so, resulting in personal injury or damage to the chair.

To install the seat:

1. Set the seat towers to the desired height. To change the seat height, see VI. “Comfort Adjustments.”
2. Remove the front extrusion clamp from the front extrusion. See figures 7 and 8.
3. Tilt the seat back, and slide the rear extrusion onto the rear trapeze bar.
4. Lower front extrusion onto the front trapeze bar.
5. Place the clamp bracket tab into the extrusion retaining slot and secure the clamp with the hardware.
6. Plug the controller cable(s) into the connector on the electronics tray. See figure 4.
7. Route the cable to ensure that the cable cannot be pinched in the seat hinge.
8. Secure the controller cable to the armrest receiver with one or more wire ties.

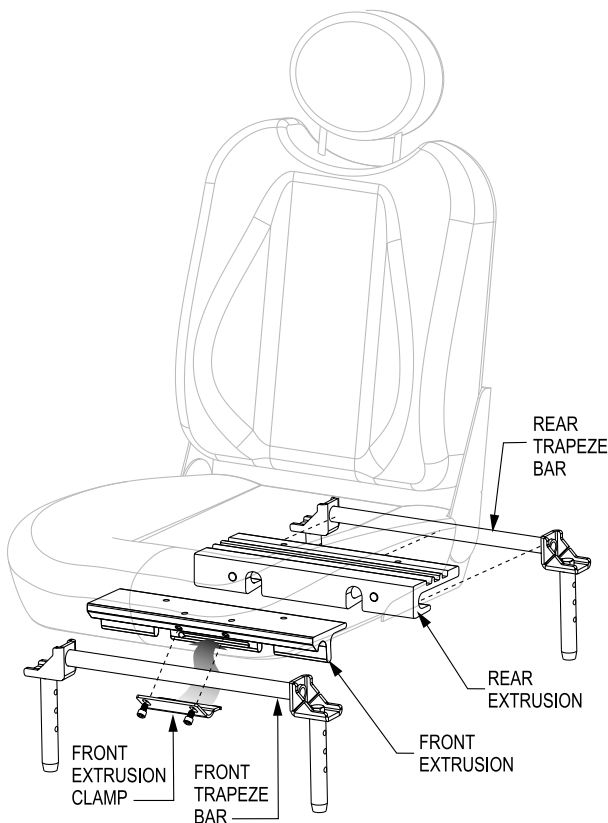

Figure 7. Universal Mounting System

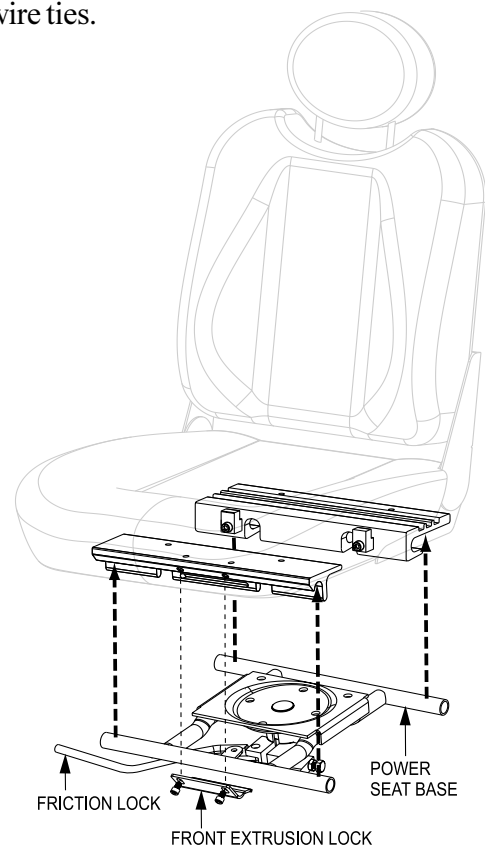

Figure 8. Universal Mounting System (Power Seat)

VI. COMFORT ADJUSTMENTS

COMFORT ADJUSTMENTS

After becoming familiar with your Jazzy's operation, you may find the need to make some adjustments to increase your comfort, such as seat height and angle, armrest angle, footrest height and angle, and the controller's position. If your Jazzy is equipped with a Synergy Seat or the Versa Tilt, refer to the information provided in separate manuals. If your Jazzy is equipped with a medium-back seat, a high-back seat, a reclining seat, or a power elevating seat, refer to the following information.



WARNING! If your Jazzy was configured at your authorized Pride Provider, please consult your healthcare professional before changing the seat position or making any other adjustment. Some adjustments may degrade your Jazzy's performance and safety by changing its center of gravity.

You may need the following to make comfort adjustments:

- metric/standard hex key set
- metric/standard socket set and ratchet
- adjustable wrench

Seat Height and Seat Angle Adjustment

There are four steel towers that connect the seat to the power base. See figures 3 and 9. You can change the seat height to one of three positions in 1-in. increments by raising the seat towers. If you raise or lower only one set of seat towers (front or rear), you can also change the seat base angle. If your Jazzy is equipped with a power elevating seat, then you change the seat height through the controller or a switch.

To change the seat height or seat angle:

1. Remove the ball detent pin from each of the four seat towers.
2. Raise or lower each seat pin to the desired position.
To change the angle, set either the front or rear seat towers higher or lower than the other.
3. Reinstall the ball detent pin into each seat tower.

Seat Position

You can move the seat forward or rearward by changing the extrusion mounting position.

To change the position:

1. Remove the seat.
2. Remove both extrusions from the bottom of the seat. See figure 7.
3. Reposition the extrusions on a different set of mounting holes. See figure 10. You must move both extrusions the same number of holes either forward or backward.
4. Fasten the extrusions back onto the bottom of the seat.
5. Reinstall the seat.

Reclining Seat

If your Jazzy is equipped with a reclining seat, you can adjust the seatback angle with the seatback release lever. The lever is located on the right side of the seat base.

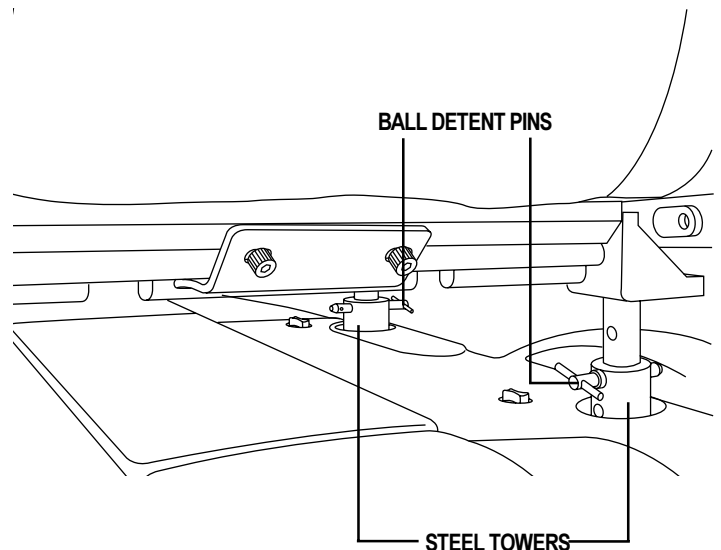

Figure 9. 1101/1121 Seat Height Adjustment

VI. COMFORT ADJUSTMENTS

To adjust the seatback angle:

1. Pull down on the lever.
2. Move the seatback down or up to the desired position.
3. Release the lever.

Seatback Angle Adjustment

If your Jazzy is equipped with an adjustable seatback, you can adjust it to four (4) different angles: 90°, 102°, 105°, or 107°.

To adjust the seatback angle:

1. Remove the adjusting screws on both seat hinges. See figure 11.
2. Set the seatback at desired angle.
3. Reinstall the screws on both seat hinges and tighten.

Armrest Width Adjustment

You can change each armrest's width independently of each other.

NOTE: Changing the armrest width may increase the overall width of your Jazzy.

To change the armrest width:

1. Locate the two armrest knobs on each side of the armrest receiver bracket. See figure 11.
2. Loosen the knobs.
3. Slide the armrests in or out to the desired width.
4. Tighten the knobs.

Armrest Angle Adjustment

To change the armrest angle:

1. Lift the armrest straight up so that it is perpendicular to the floor.
2. Loosen the jam nuts. See figure 11.
3. Loosen the adjusting screw.
4. Turn the adjusting screw clockwise to raise the front of the armrest, or turn the adjusting screw counterclockwise to lower the front of the armrest. See figure 11.
5. Tighten the jam nuts to lock the adjusting screw into place.

Footrest Height

The footrest height is easily adjusted to one of six different heights in 1-in. increments.

To raise or lower the footrest:

1. Remove the nuts and bolts from bracket. See figure 12.
2. Raise or lower the footrest to the desired height.
3. Reinstall the bolts and nuts into the footrest bracket and tighten.

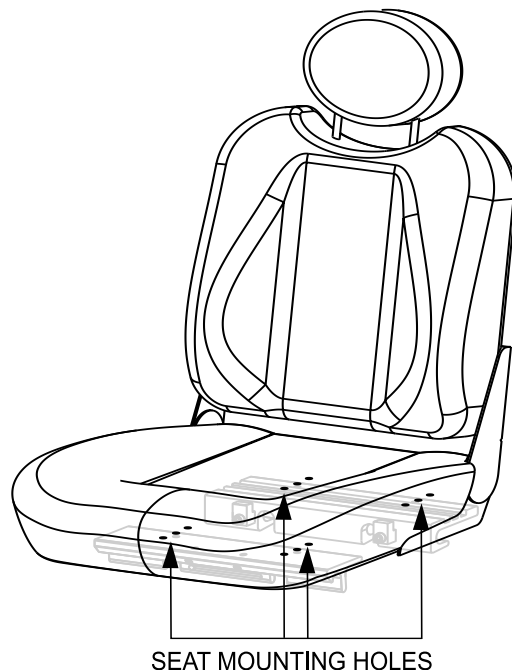

Figure 10. Seat Mounting Holes

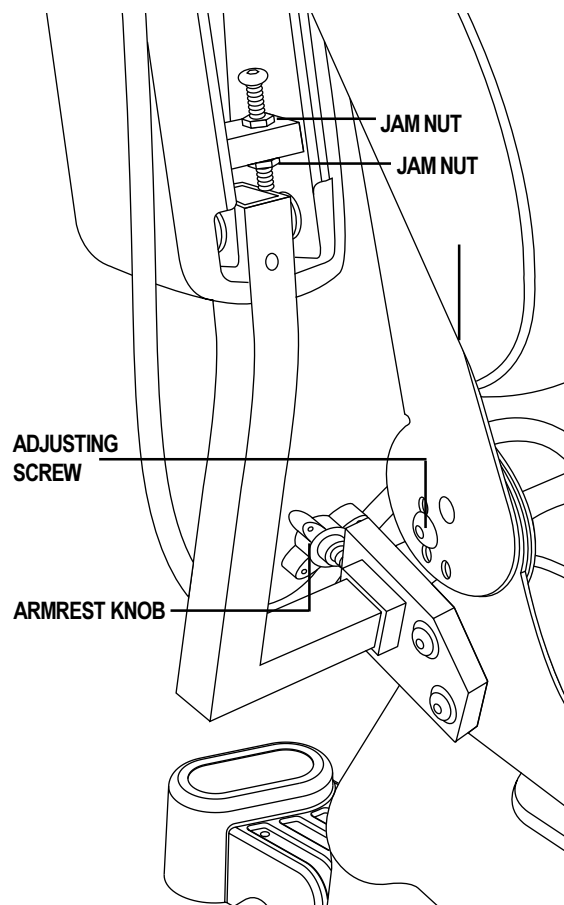

Figure 11. Seatback and Armrest Adjustments

VI. COMFORT ADJUSTMENTS

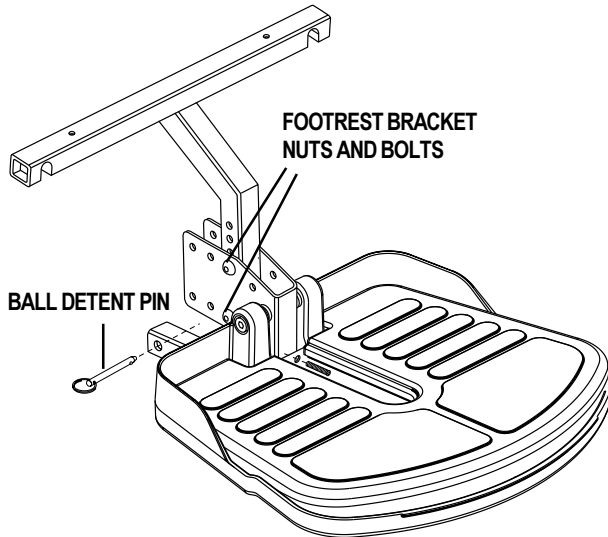

Figure 12. Footrest (Shroud removed.)

Footrest Depth

To adjust the footrest depth:

1. Remove the nuts and bolts from the bracket. See figure 12.
2. Move the footrest in or out to the desired depth.
3. Reinstall the nuts and bolts into the bracket and tighten.

Footrest Angle

You can adjust the angle of the footrest with a hex key. See figure 13.

To adjust the footrest angle:

1. Turn the setscrew counterclockwise to raise the front of the footrest.
2. Turn the setscrew clockwise to lower the front of the footrest.

Controller Position

You can position the controller for either left-hand or right-hand use.



CAUTION! Do not place the controller cable so that it can be pinched in the seat frame or the power base frame.

To change the controller position:

1. Unplug the controller connector and the charger inhibit connector from the electronics tray. See figure 4.
2. Cut the wire tie that attaches the controller cable to the armrest.
3. Use a hex key to loosen the setscrew. See figure 14.
4. Slide the controller out of the armrest.
5. Loosen the setscrew in the other armrest.
6. Place the controller in the other armrest.
7. Tighten the setscrew.
8. Use a wire tie to secure the controller cable to the armrest.
9. Plug in the controller connector and the charger inhibit connectors to the electronics tray.

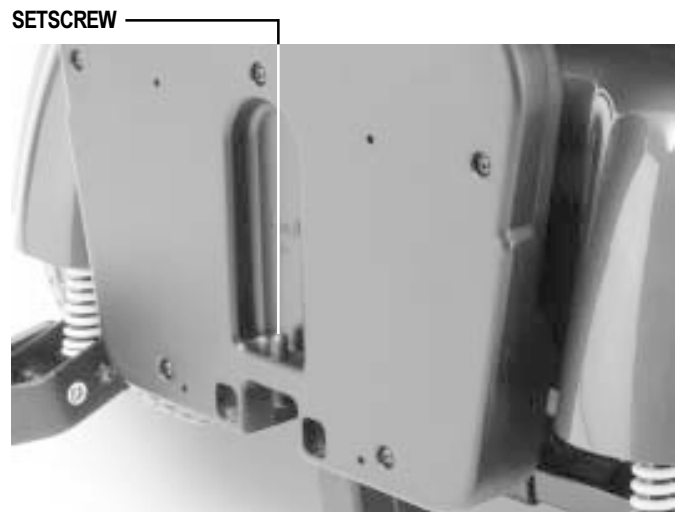

Figure 13. Footrest Angle Adjustment

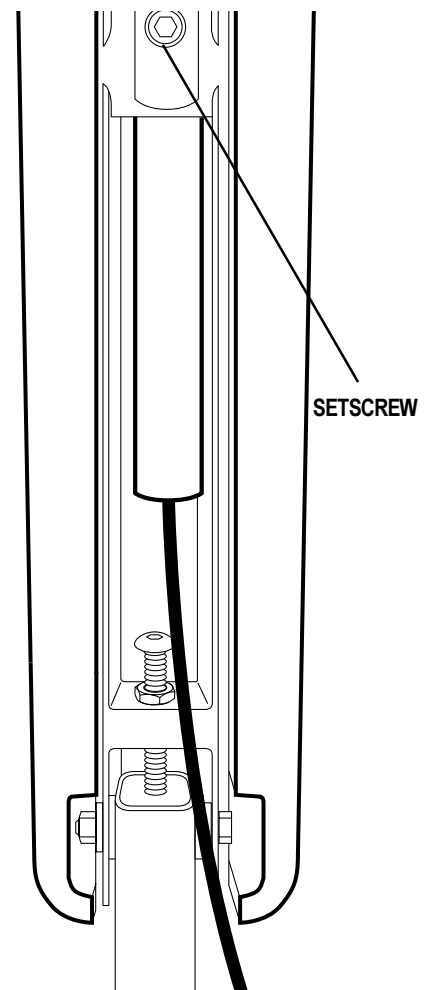

Figure 14. Underside of Armrest

VI. COMFORT ADJUSTMENTS

SFR RELEASE LEVER

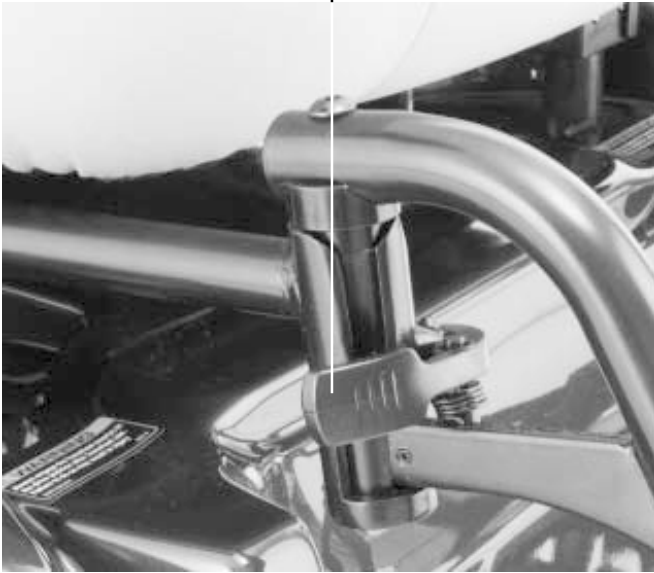

Figure 15. Swing-Away Footrests

Swing-away Footrests

Swing-away Footrests enable you to rotate the leg rests to the side before you transfer on or off your Jazzy.

To move the SFRs:

1. Push in the release lever. See figure 15.
2. Rotate the SFRs.

To adjust the SFR length:

1. Remove the two screws from the side of each leg rest extension. See figure 17.
2. Slide the leg rest in or out to the desired length.
3. Reinstall the two screws and tighten.

Elevating Leg Rests (Optional)

Elevating Leg Rests (ELRs) offer an infinite range of adjustment for the leg angle and a footrest adjustment range of 12–19 in.

To adjust the ELR angle:

1. Press the release lever. See figure 16.
2. Move the leg rest to the desired angle.

To adjust the ELR length:

1. Remove the two screws from the side of each leg rest extension. See figure 17.
2. Slide the leg rest in or out to the desired length.
3. Reinstall the two screws.

RELEASE LEVER

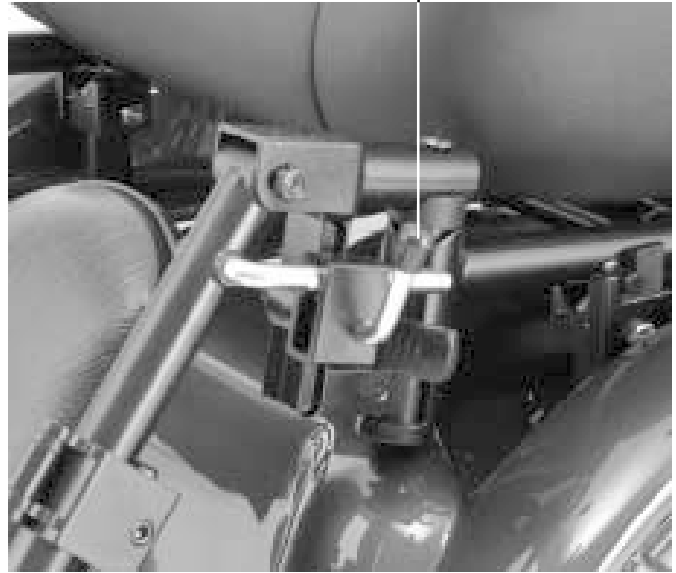

Figure 16. Elevating Leg Rests

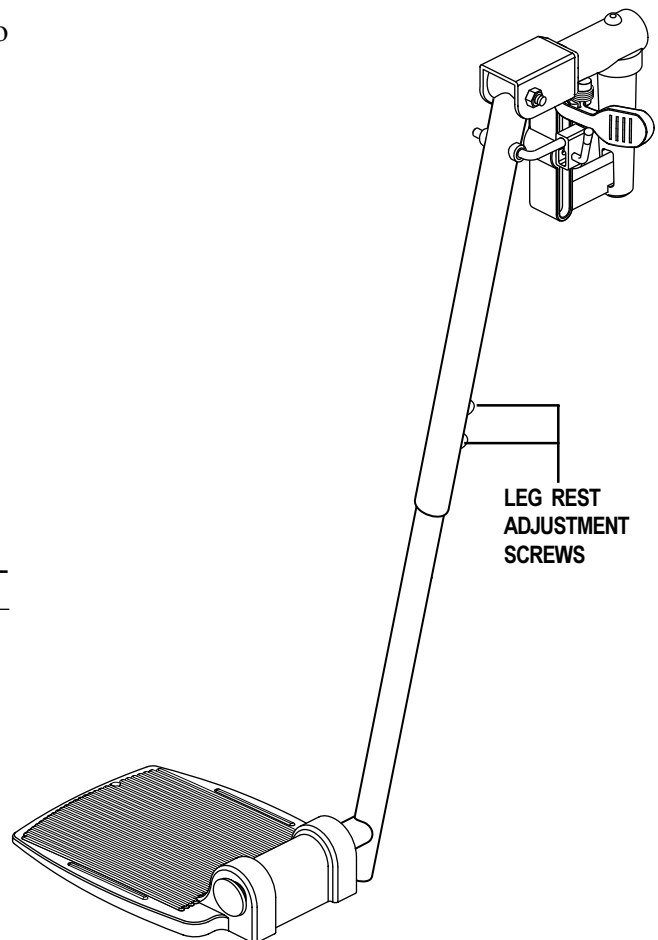

Figure 17. Elevating Leg Rests (Swing-away is similar.)

VI. COMFORT ADJUSTMENTS

Anti-Tip Wheels

The anti-tip wheels are designed to give your Jazzy increased stability on rough surfaces. The anti-tip wheels are preset at the factory to a height of 1/2-in. off the ground. This setting is for smooth surfaces or indoor use only. If you plan on using your Jazzy on rough surfaces, it may be necessary to adjust the anti-tip wheels to better suit your needs. The anti-tip wheels may need adjustment if either of the following occur:

- When coming to a stop, your Jazzy tips forward excessively.
- The anti-tip wheels constantly rub the ground.



WARNING! Consult your authorized Pride Provider before attempting to change the anti-tip wheel height! Changing the anti-tip wheel height affects handling under deceleration!

WARNING! The higher you raise the anti-tip wheels, the more you increase your power chair's tendency to tilt forward when coming to a stop. You can compensate for this by having your authorized Pride Provider make a small adjustment to the pre-programmed deceleration setting in the controller or by moving the seat assembly further to the rear of your power chair.

To adjust the anti-tip wheels:

1. Remove the anti-tip wheel. See figure 18.
2. Remove the nut and bolt on the anti-tip bracket. See figure 18.
3. Raise or lower the anti-tip wheel.
4. Reinstall the nut and bolt on the anti-tip bracket.
5. Reinstall the wheel.
6. Raise or lower the other anti-tip bracket so that it is at the same height.

NOTE: Each drive tire must have at least 30 psi in order for the anti-tip wheels to be properly adjusted.

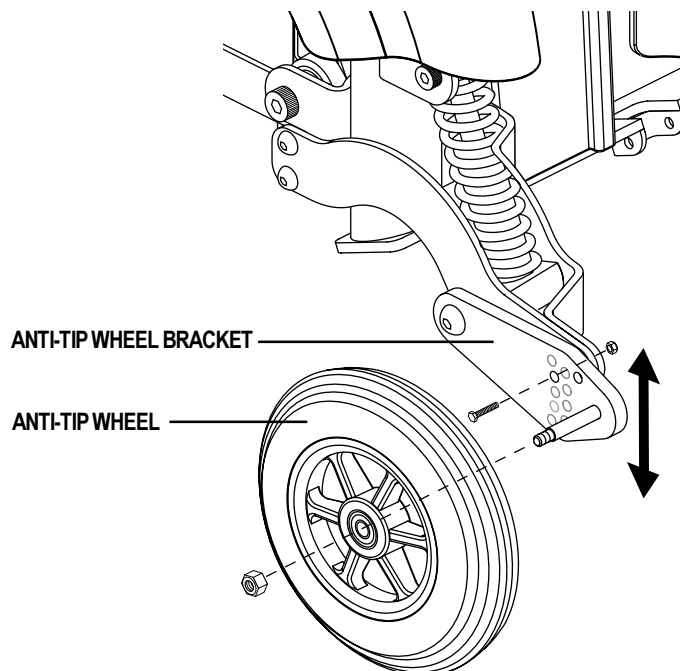

Figure 18. Anti-Tip Wheel Assembly

VI. COMFORT ADJUSTMENTS

Power Elevating Seat Option

Your Jazzy may be equipped with a power elevating seat actuator. See figure 19. The power elevating seat is equipped with a system that reduces the power chair's speed by one half whenever the seat is elevated more than 1-2 inches.

The power elevating seat can enhance the capabilities of the Jazzy in several ways:

- By elevating the seat, your level of reach is extended to allow more freedom and independence in many environments.
- You can easily adjust the Jazzy's seat height to any surface to which you want to transfer. The seat swivels 90 degrees to whichever side the joystick is located.
- By raising your seat, you are closer to the eye level of standing persons. This provides better interaction.

For all the benefits your elevating seat can provide you, there are limitations. Observe the following precautions in order to ensure safe use of the Jazzy Elevating Seat option.

- Read and understand this owner's manual thoroughly before operating the Jazzy.
- Always fasten the positioning belt when operating the elevating seat.
- Operate the Jazzy only on a flat level surface whenever the elevating seat is raised from its lowest position.

WARNING! The power elevating seat option is intended for use on a level surface only. Never raise the seat from its lowest position on an inclined surface. Failure to heed this warning can result in the Jazzy tipping over and causing injury.



WARNING! Never raise the seat from its lowest position when operating your Jazzy on bumpy or uneven surfaces. Failure to heed this warning can result in the Jazzy tipping over and causing injury.

WARNING! Never raise the power elevating seat while your Jazzy is in the freewheel mode.



CAUTION! Always fasten the positioning belt when operating the power elevating seat. The power elevating seat option is equipped with a system that reduces your Jazzy's speed by one half when the seat is elevated more than 1 – 2 inches. Always check to be sure this system is operating properly before using your Jazzy.

NOTE: Be sure you are on a flat level surface before activating the power elevating seat.



Figure 19. Power Elevating Seat Actuator

VI. COMFORT ADJUSTMENTS

Power Elevating Seat Operation

You can control the power seat through either the toggle switch located on the armrest or through your controller. For information on how to raise and lower your power seat through your controller, see VIII. "Operation."

To operate the power elevating seat:

1. Push the toggle switch forward to raise the seat. See figure 20. When you release the toggle, the seat will stop. Once the seat reaches its highest extension, the lift action stops; you should continue to hear and/or feel the lift motor running. This is because there is a clutch mechanism that allows the motor to continue running after the lift has reached its limit. This clutch works at both the top and bottom extensions of the lift.



WARNING! Do not allow the motor to run more than a few seconds after the mechanism reaches the top or bottom limit.

2. Pull the toggle switch rearward to return the seat to its lowest position. When returning to the lowest position, always be sure that the mechanism has reached its lowest limit.

To use the swivel feature:

1. Locate the swivel lever under the seat. It is located on the opposite side of the controller.
2. Push down on the lever to rotate the seat in 90° increments.



Figure 20. Toggle Switch

VII. BATTERIES AND CHARGING

BATTERIES AND CHARGING

The Jazzy uses two long-lasting, 12-volt, deep-cycle batteries. These batteries are sealed and maintenance free. Since they are sealed, there is no need to check the electrolyte (fluid) level. Deep-cycle batteries are designed to handle a longer and deeper discharge. Though they are similar in appearance to automotive batteries, they are not interchangeable. Automotive batteries are not designed to handle a long, deep discharge, and also are unsafe for use in power chairs.



WARNING! Battery posts, terminals, and related accessories contain lead and lead compounds. Wash hands after handling.

Charging the Batteries

The battery charger is essential in providing long life for your Jazzy batteries. See figure 3. The battery charger is designed to optimize your Jazzy's performance by charging the batteries safely, quickly, and easily. The charging system consists of the charger, the charger fuse, and the ammeter. The onboard charger is located underneath the electronics tray. See figure 3. The charger has an in-line fuse that protects the ammeter, which is located on the electronics tray for easy viewing. The ammeter indicates the rate of charge necessary to fully recharge the batteries. It is also a good indication of whether or not the charger is working. The ammeter and the charger are only functional when the charger power cord is plugged into a wall outlet.



WARNING! You must recharge your Jazzy's batteries with the supplied onboard or off-board charging system. Do not use an automotive-type battery charger.

WARNING! Never use an extension cord to plug in your battery charger. Plug the charger directly into a properly wired standard wall outlet.

To charge the batteries using the onboard charger:

1. Position the rear of your Jazzy close to a standard wall outlet.
2. Be certain the controller power is turned off and the freewheel levers are in the engaged position. See IV. "The Jazzy 1101/1121."
3. Plug the charger AC power cord into the receptacle on the power base, then into the wall outlet. The Jazzy incorporates an inhibit function that disables the power chair when the charger is plugged into a wall outlet.
4. The ammeter indicates how much charge is needed to fully charge the batteries. Wait about a minute for the charger to warm up. The ammeter may move as high as 5.5 amps, then gradually move back down to 0 amps as the batteries charge.
5. We recommend you charge the batteries for 8 to 14 hours. As the batteries charge, the ammeter needle slowly drops to 0. When the batteries are fully charged, the needle vibrates on or about the 0 mark on the ammeter.
6. When your Jazzy's batteries are fully charged, wind up the charger AC power cord using the hook and loop strap and place the cord back into the Jazzy's electronics tray.

To charge the batteries using the off-board charger:

1. Position your Jazzy next to a standard wall outlet.
2. Be certain the controller power is turned off.
3. Plug the off-board charger into the off-board charger/programming socket on the controller. See figures 21, 22a, 23, and 25.
4. Plug the off-board charger into the wall outlet.
5. If it is a Pride off-board charger, then there are two lights in it. The red light indicates that power to the off-board charger is on. The green light indicates that the batteries are fully charged. If it is not a Pride off-board charger, then follow the instructions that came with it.
6. When the batteries are fully charged, unplug the off-board charger from the wall outlet and from the controller.

VII. BATTERIES AND CHARGING

Battery Break-in

To break in new batteries for maximum efficiency:

1. Fully recharge any new battery prior to its initial use. This brings the battery up to about 90% of its peak performance level.
2. Operate your Jazzy throughout the house and yard. Move slowly at first, and don't stray too far until you become accustomed to the controls and break in the batteries.
3. Give the batteries another full charge of 8 to 14 hours and operate your Jazzy again. The batteries will now perform at over 90% of their potential.
4. After four or five charging cycles, the batteries will top off at 100% charge and last for an extended period.

Frequently Asked Questions (FAQs)

How does the charger work?

The battery charger takes the standard wall outlet voltage of 120 VAC (alternating current) and converts it to 24 VDC (direct current). The Jazzy batteries use direct current to run your power chair. When the battery voltage is low, the charger works harder to charge the battery. This is why the ammeter initially reads 5 or more amps. As the battery voltage approaches full charge, the charger doesn't work as hard to complete the charging cycle. This explains why the ammeter drops as it approaches a full charge. When the battery is fully charged, the amperage from the charger is nearly at zero. This is how the charger maintains a charge but does not overcharge the battery.

Can I use a different battery charger?

You should use the charger supplied with the Jazzy. It is the safest, most efficient tool to charge the batteries. We do not recommend using other types of chargers (e.g., an automotive battery charger). Your Jazzy's charger will not operate after the batteries have been discharged to nearly zero voltage. If this happens, call your authorized Pride Provider for assistance.

How often must I charge the batteries?

Many factors come into play when deciding how often to charge the batteries. You may use your Jazzy all day on a daily basis or you may not use it for weeks at a time.

■ Daily Use

If you use your Jazzy on a daily basis, charge the batteries as soon as you are finished using your Jazzy. Your Jazzy will be ready each morning to give you a full day's service. It is recommended that you charge the batteries 8 to 14 hours after daily use. Do not charge the batteries for more than 24 hours at a charging cycle.

■ Infrequent Use

If you use your Jazzy infrequently (once a week or less), you should charge the batteries at least once per week for 12 to 14 hours.

NOTE: Keep your batteries fully charged and avoid deeply discharging your batteries. Do not charge the batteries for more than 24 hours at a charging cycle.

VII. BATTERIES AND CHARGING

How can I get maximum range or distance per charge?

Rarely do you have an ideal driving situation such as smooth, flat, hard terrain with no wind, hills, or curves. More often you are presented with hills, sidewalk cracks, uneven and loosely packed surfaces, curves, and wind. All of these factors will affect the distance or running time per battery charge. Below are a few suggestions for obtaining the maximum range per charge:

- Always charge the batteries fully prior to your trip.
- Plan your trip in advance to avoid inclines if possible.
- Limit baggage weight to essential items.
- Try to maintain an even speed and avoid stop-and-go driving.

What type of batteries should I use?

We recommend deep-cycle batteries that are sealed and maintenance free. Both AGM and Gel-Cell are deep-cycle batteries that are similar in performance.

Use these specifications to reorder deep-cycle batteries:

| BATTERY SPECIFICATIONS | |
|------------------------|------------------------------|
| Type: | Deep-cycle (AGM or Gel-Cell) |
| Size: | NF-22 |
| Voltage: | 12V each |



WARNING! Corrosive chemicals contained in batteries. Use only AGM or Gel-Cell batteries to reduce the risk of leakage or explosive conditions.

Why do my new batteries seem weak?

Deep-cycle batteries employ a much different chemical technology than that used in car batteries, nickel-cadmium (nicads), or in other common battery types. Deep-cycle batteries are specifically designed to provide power, drain down their charge, and then accept a relatively quick recharge. Lead-acid batteries should be charged as often as possible. They do not have a “memory” like nickel-cadmium batteries.

We work closely with our battery manufacturer to provide a battery that best suits your Jazzy’s specific demands. Fresh batteries arrive regularly at Pride and are promptly shipped with a full charge. During shipping, the batteries encounter temperature extremes that may influence initial performance. Heat robs the charge from the battery, and cold slows the power available and extends the time needed to recharge the battery (just as with a car battery).

It might take a few days for the temperature of the battery to stabilize and adjust to its new ambient temperature. More importantly, it will take a few “charging cycles” (a partial drain— then a full recharge) to establish the critical chemical balance that is essential to the battery’s peak performance and long life. It will be well worth it to take the time to break in your battery properly.

NOTE: The useful life of a battery is quite often a reflection of the care it receives.

VII. BATTERIES AND CHARGING

How can I ensure maximum battery life?

A fully charged deep-cycle battery will provide reliable performance and extended battery life. Keep your Jazzy's batteries fully charged whenever possible. Batteries that are regularly and deeply discharged, infrequently charged, or stored without a full charge may be permanently damaged, causing unreliable Jazzy operation and limited battery life.

How should I store my Jazzy and its batteries?

If you do not use your Jazzy regularly, we recommend maintaining battery vitality by charging the batteries at least once per week.

If you do not plan on using your Jazzy for an extended period, fully charge the batteries prior to storage. Disconnect the battery harnesses and store the Jazzy in a warm, dry environment. Avoid temperature extremes, such as freezing and excessively hot conditions, and never attempt to charge a frozen battery. A cold or frozen battery should be warmed for several days prior to recharging.

What about public transportation?

AGM and Gel-Cell batteries are designed for application in power chairs and other mobility vehicles. These batteries are Federal Aviation Administration (FAA) approved, allowing safe transportation on aircraft, buses, and trains, as there is no danger of spillage or leakage. We suggest you contact the carrier's ticket counter in advance to determine that carrier's specific requirements.

What about shipping?

If you wish to use a freight company to ship your Jazzy to your final destination, repack your Jazzy in the original shipping container and ship the batteries in separate boxes.

VIII. OPERATION

VSI ELECTRONIC CONTROLLER

The *electronic controller* is what you use to operate your power chair. The electronic controller enables you to move the power chair, as well as monitor battery charge, electronic controller functions, and the condition of your electrical system. The VSI electronic controller is an *integral electronic controller*. All of the electronics necessary to operate the power chair are contained in one module. See figure 21. Typically, the VSI is mounted to one of the armrests and is connected to the motors, batteries, and the onboard charger at the power base. The VSI may be used to control some *optional systems* such as power elevating seats and lights.

The controller supplied with your power chair has been pre-programmed to meet the needs of the end user. The program is set using either a personal computer with software provided by the controller manufacturer or with a hand-held programmer, also provided by the controller manufacturer.



WARNING! The controller program can affect speed, acceleration, deceleration, and braking. But if it is programmed incorrectly or outside of the safe limits as determined by your healthcare professional, it can create a dangerous situation. Only the power chair manufacturer, an authorized representative of the manufacturer, or a trained service technician should program the controller.

The VSI consists of:

1. joystick
2. keypad
3. off-board charger/programming socket
4. actuator connector (*optional*)
5. controller connector
6. charger inhibit connector

Joystick

The *joystick* controls the direction and speed of your power chair. When you move the joystick from the *neutral* (center) position, the electromagnetic brakes release and allow your power chair to move. The further you push the joystick from its neutral position, the faster your power chair moves. When you release the joystick and allow it to return to the neutral position, you engage the electromagnetic brakes. This causes your power chair to decelerate and come to a complete stop.

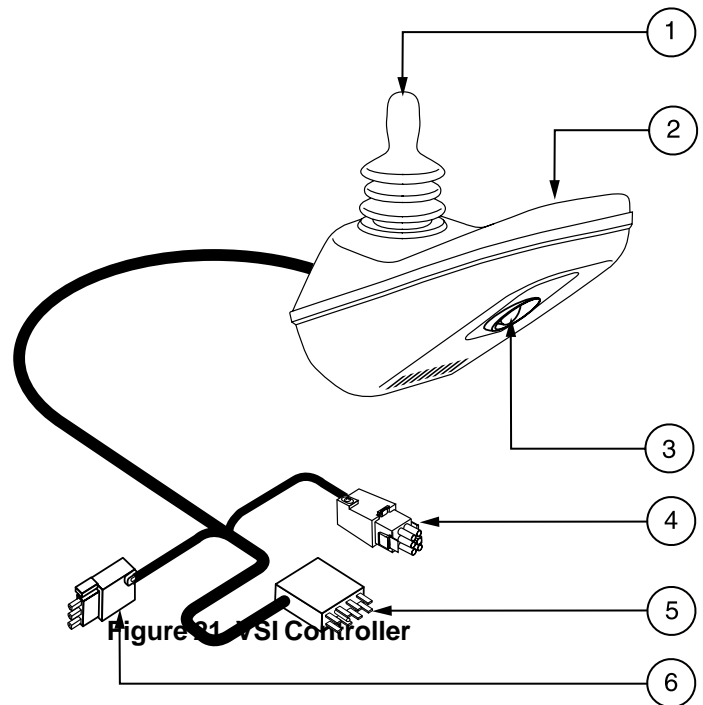

Figure 21. VSI Controller Keypad



WARNING! If your power chair begins to move in an unexpected manner, immediately release the joystick. Unless the joystick is damaged, this action should stop your power chair.

Keypad

The *keypad* is located in front of the joystick. It contains keys necessary to operate your power chair. See figure 22.

VIII. OPERATION

On/Off Key

The *on/off key* turns the VSI on and off.



WARNING! Unless faced with an emergency situation, do not use the on/off key to stop the power chair. This will cause the power chair to stop abruptly.

WARNING! Always turn the power off when you are stationary to prevent unexpected movement.

Battery Condition Meter

The *battery condition meter* is a 10-segment illuminated display located in front of the joystick. It consists of red, yellow, and green lights. When the lights are on, it indicates that there is power to the VSI. The lights also indicate battery status, VSI operational status, and electrical system status.

- **Red, yellow, and green lights lit:** Battery charged; VSI operational, and electrical system OK.
- **Red and yellow lights lit:** Charge battery if possible; VSI operational, and electrical system OK.
- **Red lights only lit or slow flash:** Charge battery as soon as possible; VSI operational, and electrical system OK.

NOTE: When the batteries approach a discharged state, the first red light will begin to slowly flash, reminding you the batteries need to be charged immediately!

- **Rapid flash of lights:** Indicates a fault in the VSI or the electrical system. Refer to “VSI Error Codes.”
- **Ripple up and down of lights:** The joystick was not in the neutral position when the controller was turned on. If you get “ripple up and down of lights”, turn off the controller, allow the joystick to return to the neutral position, then turn on the controller.

NOTE: If you still get “ripple up and down of lights,” contact your authorized Pride Provider.

Speed/Profile Keys

The *speed/profile keys* control either the speed setting or the drive profile. Press the speed/profile increase key to increase the speed setting or change the drive profile to a higher number. Press the speed/profile decrease key to decrease the speed setting or change the drive profile to a lower number. The speed setting or drive profile is displayed on the *maximum speed/profile indicator*. If your power chair was programmed with a drive profile, contact your authorized Pride Provider for more information.

NOTE: We recommend that the first few times you operate your power chair, you use the lowest speed setting until you become familiar with your new power chair.

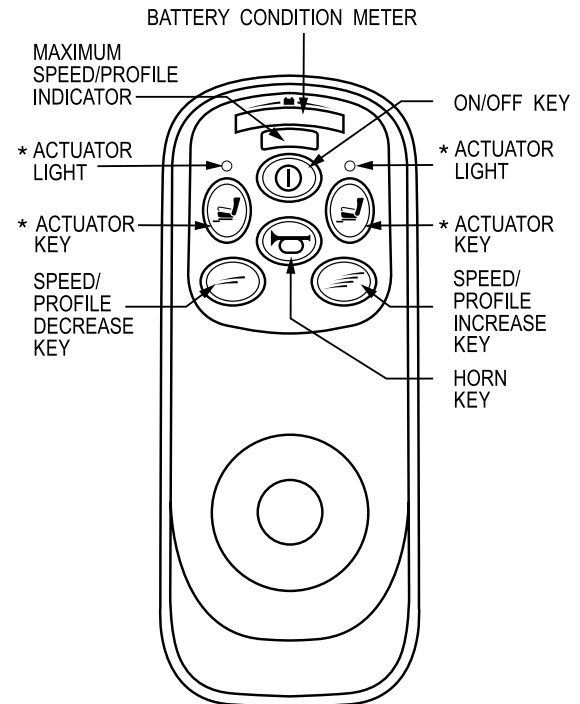

*For optional equipment on some models.

Figure 22. VSI Controller Keypad

VIII. OPERATION

Actuator Keys and Actuator Lights (For Optional Equipment)

Actuator keys and *actuator lights* are used for optional equipment such as power elevating seats or power elevating leg rests. For specific operation of the actuator keys and actuator lights, contact your authorized Pride Provider.

Horn Key

The *horn key* activates the horn.

Locking/Unlocking the VSI

The VSI has a feature that enables you to *lock* your power chair to prevent unauthorized use.

To lock the VSI:

1. With the VSI switched on, press and hold the on/off button. After 1 second, the VSI should beep.
2. Release the on/off button.
3. Push the joystick to the full forward position until the VSI beeps.
4. Pull the joystick to the full rearward position until the VSI beeps.
5. Release the joystick. There should be a long beep.
6. The VSI is now locked.

To unlock the VSI:

1. Press the on/off button and power on the VSI. The maximum speed/profile indicator should ripple up and down.
2. Push the joystick to the full forward position until the VSI beeps.
3. Pull the joystick to the full rearward position until the VSI beeps.
4. Release the joystick. There should be a long beep.
5. The VSI is now unlocked.

NOTE: If the above procedure fails to either lock or unlock the VSI, contact your authorized Pride Provider.

Off-board Charger/Programming Socket

The *off-board charger/programming socket* is located on the front of the VSI. If you use an off-board charger, the charger current should not exceed 12 amps. Contact your authorized Pride Provider for more information.



CAUTION! Only chargers with Neutrik NC3MX plugs should be connected to the off-board charger/programming socket. See your authorized Pride Provider for more information.

Actuator Connector

The *actuator connector* connects the VSI to optional powered systems such as an elevating seat or lighting system.

Controller Connector

The *controller connector* connects the VSI to the power chair's batteries, motors, and motor brakes.

Charger Inhibit Connector

The *charger inhibit connector* connects the VSI to the onboard battery charger. This connection provides an inhibit that *disables* the VSI when the battery charger is on. The charger inhibit connector is coded with colored dots. The dots are positioned so that you align the flat side of the male connector with the flat side of the female connector before making the connection.



CAUTION! Failure to properly align the connectors can result in damage to the VSI, the charger, and the connectors.

Thermal Rollback

The VSI controller is equipped with a *thermal rollback* circuit. This circuit monitors the temperature of the controller, which roughly translates to motor temperature. In the event that the VSI controller becomes excessively hot (above 140° F), motor current (amperage) is reduced. For every degree above 140° F, the motor current limit is reduced by .55 amps until the VSI controller reaches 158° F, at which time the current output is reduced to zero. This reduces your power chair's "power," which could also reduce your power chair's speed, and allows the electrical components and motors to cool down. When the temperature returns to a safe level, your power chair resumes its normal operation.

VSI Error Codes

The VSI controller is designed with the user's safety as the prime consideration. It incorporates many sophisticated self-test features which search for potential problems at a rate of 100 times per second. If the VSI detects a problem either in its own circuits or in the power chair's electrical system, it may decide to stop the power chair, depending on the severity of the problem. The VSI is designed to maximize the user's safety under all normal conditions. The table below identifies the individual error codes. *Error codes* are displayed as a rapid flashing of the battery condition meter lights. If you get one of these error codes, contact your authorized Pride Provider.

| FLASHING LIGHTS | DIAGNOSIS AND SOLUTION |
|-----------------|----------------------------------------------------------------------------------------------------------------------------------------------------------------------|
| 1 | The battery needs charging or there is a bad connection to the battery. Check the connections to the battery. If the connections are good, try charging the battery. |
| 2 | The left motor has a bad connection. Check the left motor connection. |
| 3 | The left motor has a short circuit to a battery connection. Contact your authorized Pride Provider. |
| 4 | The right motor has a bad connection. Check the right motor connection. |
| 5 | The right motor has a short circuit to a battery connection. Contact your authorized Pride Provider. |
| 6 | The power chair is being inhibited by the battery charger. Unplug the battery charger. |
| 7 | A joystick fault is indicated. Make sure that the joystick is in the neutral (center) position before turning on the controller. |
| 8 | A controller system fault is indicated. Make sure that all connections are secure. |
| 9 | The parking brakes have a bad connection. Check the parking brake and motor connections. Make sure the controller connections are secure. |
| 10 | An excessive voltage has been applied to the controller. This is usually caused by a poor battery connection. Check the battery connections. |

VIII. OPERATION

PILOT CONTROLLER

The Pilot controller is an integral electronic controller. All of the electronics necessary to operate the power chair are contained in one module. See figure 22a.

The Pilot consists of:

1. joystick
2. on/off button
3. battery condition meter
4. speed control knob
5. off-board charger/programming socket
6. 9-pin controller connector
7. 3-pin charger inhibit connector

Typically, the Pilot is mounted to one of the armrests and is connected to the motors, batteries, and the onboard charger at the electronics tray.

Joystick

The joystick controls the direction and speed of your power chair. When you move the joystick from the neutral (center) position, the electromagnetic brakes release and allow your power chair to move. The further you push the joystick from its neutral position, the faster your power chair moves. When you release the joystick and allow it to return to the neutral position, you engage the electromagnetic brakes. This causes your power chair to decelerate and come to a complete stop.

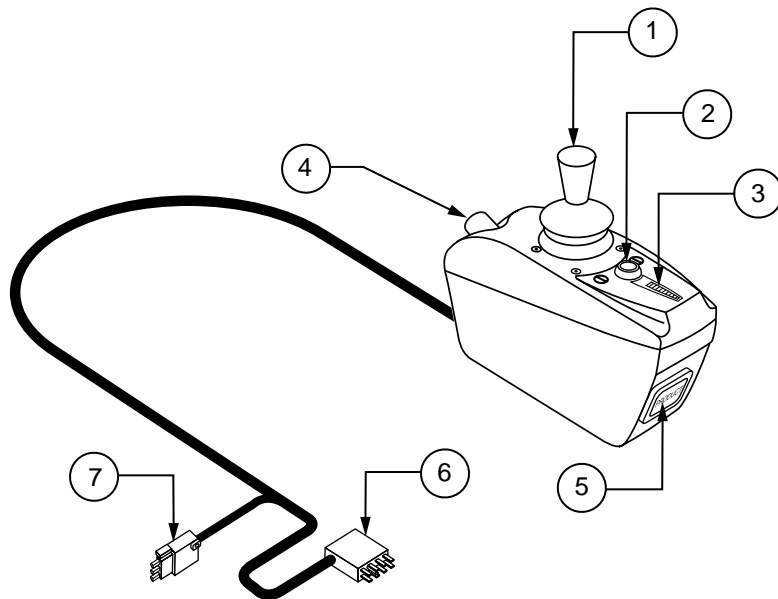

Figure 22a. The Pilot Controller



WARNING! If your power chair begins to move in an unexpected manner, immediately release the joystick. Unless the joystick is damaged, this action should stop your power chair.

On/Off Button

This is a green button located in front of the joystick. It turns the Pilot on and off.



WARNING! Unless faced with an emergency situation, do not use the on/off push button to stop the chair. This will cause the power chair to stop abruptly.

WARNING! Always turn the power off when you are stationary to prevent unexpected movement.

VIII. OPERATION

Battery Condition Meter

The battery condition meter is located in front of the joystick. This is a 10-segment illuminated display that indicates that the Pilot is turned on and also gives the battery status, the Pilot status, and the electrical system status.

- **Red, yellow, and green lights lit:** Battery charged; Pilot and electrical system OK.
- **Red and yellow lights lit:** Charge battery if possible; Pilot and electrical system OK.
- **Red lights only lit or slow flash:** Charge battery as soon as possible; Pilot and electrical system OK.
- **Rapid flash of lights:** Indicates a fault in the Pilot or the electrical system. Refer to “Pilot Trouble Codes.”
- **Ripple up and down of lights:** The joystick was not in the neutral position when the controller was turned on. If you get “ripple up and down of lights”, turn off the controller, allow the joystick to return to the neutral position, then turn on the controller.

NOTE: If you still get “ripple up and down of lights”, contact your authorized Pride Provider.

NOTE: When the batteries approach a discharged state, the first red light will begin to slowly flash, reminding you the batteries need to be charged immediately!

Speed Control Knob

Sets the maximum speed of the power chair: clockwise to increase, counterclockwise to decrease.

NOTE: We recommend that the first few times you operate your power chair, you turn the speed control to the slowest setting until you become familiar with your new power chair.

Off-board Charger/Programming Socket

You may use an off-board charger to charge the power chair batteries through the 3-pin socket located on the front of the Pilot. If you use an off-board charger, the charger current should not exceed 12 amps. Contact your authorized Pride Provider for more information.



CAUTION! Only chargers with Neutrik NC3MX plugs should be connected to the off-board charger/programming socket. See your authorized Pride Provider for more information.

NOTE: The off-board charger/programming socket may also be used for reprogramming the Pilot. Contact your authorized Pride Provider for more information.

9-pin Controller Connector

This connects the Pilot to the power chair’s batteries, motors, and motor brakes.

3-pin Charger Inhibit Connector

This connects the Pilot to the onboard battery charger. This connection provides an inhibit that disables the Pilot when the battery charger is on. The charger inhibit connector is coded with colored dots. The dots are positioned so that you align the flat side of the male connector with the flat side of the female connector before making the connection.



CAUTION! Failure to properly align the connectors can result in damage to the Pilot, the charger, and the connectors.

VIII. OPERATION

Thermal Rollback

The Pilot is equipped with a thermal rollback circuit. This circuit monitors the temperature of the motors and the Pilot. In the event that either one of the motors or the Pilot becomes excessively hot (above 122° F), the Pilot reduces the motor voltage. For every degree above 122° F, the controller reduces the voltage by 5 volts. This reduces your power chair's speed and allows the electrical components to cool down. When the temperature returns to a safe level, your power chair resumes its normal speed.



WARNING! Under strenuous driving conditions, it is possible for the bottom and side case temperature of the Pilot to exceed 105° F. DO NOT touch the side or bottom of the Pilot case under these circumstances.

Pilot Trouble Codes

In addition to indicating the current state of battery charge, the battery condition meter can also indicate possible problems with your power chair. The battery condition meter has ten lights. The lights provide information by the number of lights that are flashing. If any of the meter lights are flashing rapidly, the controller may be indicating a fault. For instance, if the first light is flashing rapidly, the battery voltage is nearly depleted. The following is a list of the possible errors signified by the rapidly flashing meter lights. When you get a trouble code, contact your authorized Pride Provider.

| FLASHING LIGHTS | DIAGNOSIS | SOLUTION |
|-----------------|---------------------------|------------------------------------|
| 10 | High Battery Voltage | Check batteries. |
| 9 | Solenoid Brake Fault | Check motor/brake wiring. |
| 8 | Possible Controller Fault | See authorized Pride Provider. |
| 7 | Possible Joystick Fault | See authorized Pride Provider. |
| 6 | Inhibit Active | Unplug charger. Check connections. |
| 5 | Right Motor Wiring Fault | Check right motor wiring. |
| 4 | Right Motor Disconnected | Check right motor wiring. |
| 3 | Left Motor Wiring Fault | Check left motor wiring. |
| 2 | Left Motor Disconnected | Check left motor wiring. |
| 1 | Low Battery Voltage | Check batteries/battery wiring. |

VIII. OPERATION

REMOTE PLUS CONTROLLER

The Remote Plus is a modular electronic control system. The electronics necessary to operate the power chair are contained in several modules located on different parts of your power chair.

The Remote Plus system consists of the following components:

- master remote
- communications cable(s)
- power module
- motor wiring harnesses
- battery wiring harnesses
- actuator lighting module (for optional equipment)

The master remote is located typically on the end of an armrest. The other components are located inside the power base.

Remote Plus Master Remote

The Remote Plus master remote consists of the following (see figure 23):

1. joystick
2. keypad
3. controller communications cable
4. off-board charger/programming socket

Joystick

The joystick controls the direction and speed of your power chair. When you move the joystick from the neutral (center) position, the electromagnetic brakes release and allow your power chair to move. The further you push the joystick from its neutral position, the faster your power chair moves. When you release the joystick and allow it to return to the neutral position, you engage the electromagnetic brakes. This causes your power chair to decelerate and come to a complete stop.

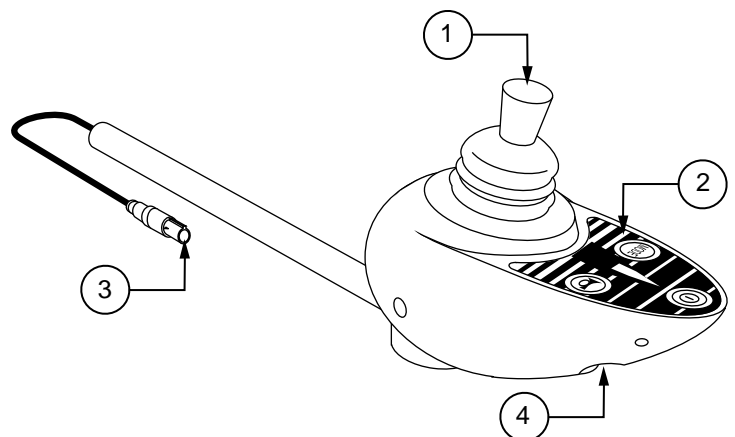

Figure 23. Remote Plus Master Remote



WARNING! If your power chair begins to move in an unexpected manner, immediately release the joystick. Unless the joystick is damaged, this action should stop your power chair.

Keypad

The keypad is located directly in front of the joystick. See figure 24. It contains keys that you will use to control your power chair.

On/Off Key

The on/off keys turns the system power on and off.

VIII. OPERATION



WARNING! Unless faced with an emergency situation, do not use the on/off key to stop the chair. This will cause the power chair to stop abruptly.

WARNING! Always turn the power off when you are stationary to prevent unexpected movement.

Mode Key

Press the key to change speed setting or to activate the power accessories. See “Speed Settings” or “Power Accessories.”

Speed Setting Indicator

Indicates the selected speed setting.

Power Accessory Indicator

Indicates the selected power accessory. This is for optional accessories only.

Horn Key

The horn key activates the horn.

Right/Left Turn Indicator Keys

The right/left turn indicator keys toggle either the left or right turn indicators. Press once to turn on and press again to turn off. You can also turn off the selected indicator by pressing the opposite indicator key or the hazard key.

Light Key

The light key turns headlights/taillights on and off independent of other indicators.

Hazard Key

The hazard key toggles both turn indicators at the same time. You can only cancel this by pressing the hazard key again.

Battery Condition Meter

The battery condition meter is located in front of the joystick. This is a 10-segment illuminated display that indicates that the Remote Plus is turned on and also gives the status of the battery, the controller, and the power chair electrical system.

- **Red, yellow, and green lights lit:** Battery charged; controller and electrical system OK.
- **Red and yellow lights lit:** Charge battery if possible; controller and electrical system OK.
- **Red lights only lit or slow flash:** Charge battery as soon as possible; controller and electrical system OK.
- **Rapid flash of lights:** Indicates a fault in the controller or the electrical system. Refer to “Remote Plus Trouble Codes.”
- **Ripple up and down of lights:** The joystick was not in the neutral position when the controller was turned on. If you get “ripple up and down of lights”, turn off the controller, allow the joystick to return to the neutral position, then turn on the controller.

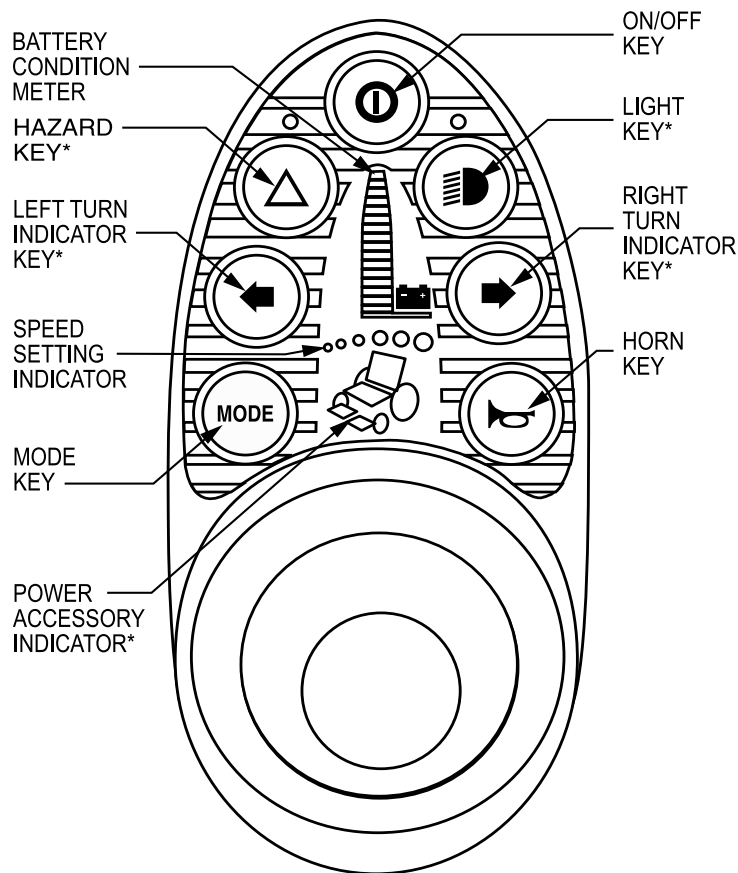

*These are optional accessories. Please contact your authorized Pride provider for more information.

Figure 24. Remote Plus Keypad

VIII. OPERATION

NOTE: If you still get “ripple up and down of lights”, contact your authorized Pride Provider.

NOTE: When the batteries approach a discharged state, the first red light will begin to slowly flash, reminding you the batteries need to be charged immediately!

Speed Settings

The Remote Plus speed settings range from 1 to 5. Typically, the slowest speed setting is 1 and the fastest speed setting is 5. The settings are indicated by the number of lights that are lit.

NOTE: The speed settings are preset at the factory. If your authorized Pride Provider changes the order of these settings, please make note of these changes. Contact your authorized Pride Provider for more information.

To select a speed setting:

1. Press the on/off key to power on the remote.
2. Press the mode key once.
3. To increase chair speed, push the joystick to the right. Each time you push the joystick, you will increase the speed setting.
4. To decrease chair speed, push the joystick to the left. Each time you push the joystick, you decrease the speed setting.
5. Once you select the desired speed setting, press the mode key once to keep the setting or push the joystick in the forward or reverse direction. The chair will resume operation at the selected speed.

NOTE: We recommend that the first few times you operate your power chair, you have your speed on the slowest setting until you become familiar with your new power chair.

Power Accessories

If your power chair is equipped with power accessories such as a power seat or power elevating leg rests, you can operate them through the remote keypad. Contact your authorized Pride Provider for information on how to operate these accessories.

Off-board Charger/Programming Socket

You may use an off-board charger to charge the power chair batteries through the 3-pin socket located on the front of the controller. See figure 23. The socket may also be used for reprogramming the controller by using a PG Drive Programmer, should this be necessary. If you use an off-board charger, the charger current should not exceed 12 amps. Contact your authorized Pride Provider for more information.



CAUTION! Only chargers with Neutrik NC3MX plugs should be connected to the charger socket. See your authorized Pride Provider for more information.

Controller Communications Cable

The controller communications cable provides the joystick module with a connection to the power module. See figure 23.

Power Module

Typically, the power module is mounted to the power base. See figure 3. The power module provides a power interface for the joystick module. It routes the battery power to the motors and other powered accessories such as lights and power seats.

VIII. OPERATION

Actuator Lighting Module (Not Shown)

The actuator lighting module is also located on the power base. The actuator lighting module provides a control and power interface between the power module, the lights, and/or the power seat actuator.

Sleep Mode

Your Remote Plus controller has a sleep mode feature. Sleep mode is a built-in circuit that automatically shuts off the main power if the joystick is not moved in any direction for approximately five minutes. The battery condition meter lights on the keypad indicate sleep mode by blinking once every five seconds. To restore power and continue, push the on/off key twice.

Thermal Rollback

The Remote Plus is equipped with a thermal rollback circuit. This circuit monitors the temperature of the motors, power module, and remote. In the event that any of them become excessively hot (above 122° F), motor voltage is reduced. For every degree above 122° F, the voltage is reduced by 5 volts. This reduces your power chair's speed and allows the electrical components to cool down. When the temperature returns to a safe level, your power chair resumes its normal speed.

Remote Plus Trouble Codes

In addition to indicating the current state of battery charge, the battery condition meter can also indicate possible problems with your power chair. The battery condition meter has ten lights. The lights provide information by the number of lights that are flashing. If any of the meter lights are flashing rapidly, the controller may be indicating a fault. For instance, if the first light is flashing rapidly, the battery voltage is nearly depleted. The following is a list of the possible errors signified by the rapidly flashing meter. When you get a trouble code, contact your authorized Pride Provider.

| FLASHING LIGHTS | DIAGNOSIS | SOLUTION |
|-----------------|---------------------------|------------------------------------|
| 10 | High Battery Voltage | Check batteries. |
| 9 | Solenoid Brake Fault | Check motor/brake wiring. |
| 8 | Possible Controller Fault | See authorized Pride Provider. |
| 7 | Possible Joystick Fault | See authorized Pride Provider. |
| 6 | Inhibit Active | Unplug charger. Check connections. |
| 5 | Right Motor Wiring Fault | Check right motor wiring. |
| 4 | Right Motor Disconnected | Check right motor wiring. |
| 3 | Left Motor Wiring Fault | Check left motor wiring. |
| 2 | Left Motor Disconnected | Check left motor wiring. |
| 1 | Low Battery Voltage | Check batteries/battery wiring. |

VIII. OPERATION

DYNAMIC DX CONTROLLER

The Dynamic DX electronic control system is a modular system. The electronics necessary to operate the power chair are contained in several modules located on different parts of your power chair.

The Dynamic DX system consists of the following components:

- Europa master remote (see figure 25)
- communications cable(s)
- power module
- motor wiring harnesses
- battery wiring harnesses
- actuator lighting module (for optional systems)

The master remote is located typically on the end of an armrest. The other components are located inside the power base.

Europa Master Remote

The Europa master remote consists of the following:

1. joystick
2. keypad
3. controller communications connector
4. off-board charger/programming socket

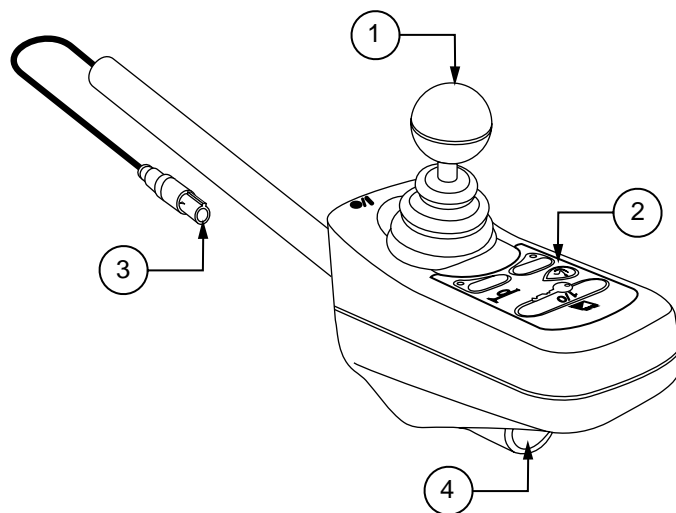

Figure 25. Europa Master Remote

Joystick

The joystick controls the direction and speed of the power chair. When you move the joystick from the neutral (center) position, the electromagnetic brake will release and allow the power chair to move. The further you push the joystick from its neutral position, the faster your power chair will move. When you release the joystick and allow it to return to the neutral position, you engage the electromagnetic brake. This helps the power chair decelerate and come to a complete stop.



WARNING! If your power chair begins to move in an unexpected manner, immediately release the joystick. Unless the joystick is damaged, this action should stop your power chair.

Out Of Neutral At Power Up

Your power chair joystick is equipped with Out Of Neutral At Power Up (OONAPU). If you power up the system and the joystick is not in the neutral position, the system status light flashes rapidly for either as long as the joystick is out of the neutral position or for five seconds. If this has happened and the all the lights on the battery condition meter are flashing, you may have set flash code 1.

Keypad

The keypad is located directly in front of the joystick. It contains keys that you will use to control your power chair.

VIII. OPERATION

On/Off Key

The on/off key turns the system power on and off.



WARNING! Unless faced with an emergency situation, do not use the on/off key to stop the chair. This will cause the power chair to stop abruptly.

WARNING! Always turn the power off when you are stationary to prevent unexpected movement.

NOTE: If the joystick is not in the neutral (center) position when you turn on the power, you may cause a fault in the system. See “Out Of Neutral At Power Up.”

System Status Light

The system status light is normally on when the system is powered up, and off when the system is powered down. It will also flash trouble codes when the system detects a fault. See “Trouble Codes.”

Magnetic Locking Area

Your power chair is equipped with a feature that enables you to “lock-out” unauthorized users. For this function, you will need the magnetic key supplied with your power chair. If you lose this key, contact your authorized Pride Provider.

To enable the lockout the system:

1. Hold the magnetic key on or near the key symbol. The system will beep and automatically power down.

NOTE: None of the remote lights should be lit.

2. Press the on/off key to power up the chair. The key symbol will flash, but you will not be able to drive your power chair. This means that the controller is still locked.
3. Hold the magnetic key on or near the key symbol again to unlock the controller. When the key symbol stops flashing, you may turn on the power chair.

NOTE: If you turn on the power chair while it is locked and don't unlock it after one minute, the power chair will automatically turn off itself.

Battery Condition Meter

The battery condition meter consists of six lights arranged in an arc over the battery icon. From left to right, the first two are red, the second two are orange and the last two are green. These lights give you an accurate indication of your usable battery capacity. If the battery has at least 85% of its rated capacity, all of the lights will be on. As the battery voltage drops, the number of lights reduces from right to left. When the battery capacity drops to 10% or below, all of the lights will flash once every second.

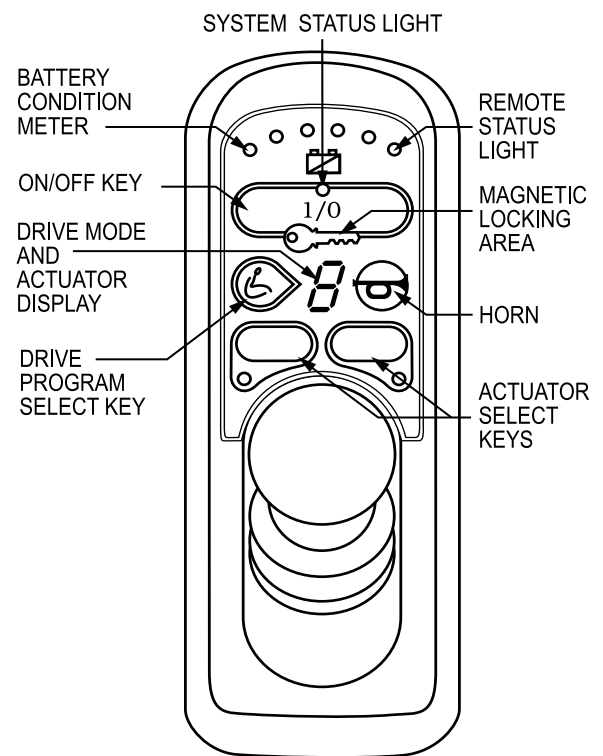

Figure 26. Europa Master Remote Keypad

VIII. OPERATION

Drive Program Select Key

The drive program select key enables you to select a drive program and an actuator mode. Your Dynamic DX controller was preprogrammed at the factory for five drive programs— 1 (slowest) to 5 (fastest). The drive mode is indicated by a number in the center of the keypad.

NOTE: The drive mode settings are preset at the factory. If your authorized Pride Provider changes these settings, please make note of these changes.

To change the drive mode program:

1. Press the drive program select key.
2. Move the joystick right to increase the drive mode program.
3. Move the joystick left to decrease the drive mode program.
4. Press the drive mode select key.

Drive Mode and Actuator Display (also Remote Status Display)

This is a seven-segment light that displays the drive program. It also displays a drive inhibit and actuator mode (if applicable), when they occur. This light will flash if there is an internal Dynamic DX Remote fault, or if an OONAPU fault has occurred. See “Out Of Neutral At Power Up.”

Power Accessories

If your power chair is equipped with power accessories such as a power seat or power elevating leg rests, you can operate them through the remote keypad. Contact your authorized Pride Provider for information on how to operate these accessories.

Horn Key

The horn key activates the horn.

Battery Saver Feature

When the battery capacity drops to below 21V (typically two lights), the controller will reduce power chair performance to conserve battery power.

Off-board Charger/Programming Socket

You may use an off-board charger to charge the power chair batteries through the 3-pin socket located on the front of the controller. The socket may also be used for reprogramming the controller by using a Dynamics Programmer, should this be necessary. If you use an off-board charger, the charger current should not exceed 8 amps. Contact your authorized Pride Provider for more information.

Sleep Mode

The power chair controller features a sleep mode. Sleep mode is a built-in circuit that will automatically shut off the main power if the joystick is not moved in any direction for a specific amount of time. This time factor is programmed into the controller. The battery condition meter on the keypad indicates sleep mode by blinking once every five seconds. To restore power and continue, push the on/off key twice.

VIII. OPERATION

Trouble Codes

The system status light is displayed within the on/off key. This light is lit if the system is turned on. It also flashes in groups called flash codes, to indicate system faults. The table below identifies the individual fault codes. If your keypad displays one of these codes, contact your authorized Pride Provider.

| FLASH CODE SEQUENCE | DIAGNOSIS | SOLUTION |
|-----------------------------|-----------------------------------|------------------------------------------|
| •—•—•— | DX Module Fault | See your authorized Pride Provider. |
| ••—••—•— | DX Accessory Fault | See your authorized Pride Provider. |
| •••—•••— | Left Motor (or Connection) Fault | Check left motor wiring. |
| ••••—••••— | Right Motor (or Connection) Fault | Check right motor wiring. |
| •••••—•••••— | Left Park Brake Fault | Check motor/brake wiring. |
| ••••••—••••••— | Right Park Brake Fault | Check motor/brake wiring. |
| •••••••—•••••••— | Low Battery Fault | Check that the battery wiring is secure. |
| ••••••••—••••••••— | Over Voltage Fault | Check that the battery wiring is secure. |
| •••••••••—•••••••••— | CANL Fault | See your authorized Pride Provider. |
| ••••••••••—••••~••••~••••~ | CANA Fault | See your authorized Pride Provider. |
| •••••••••••—••••~••••~••••~ | Stall Timeout | Turn unit on, then off. |
| ••••••~••••~••••~••••~••••~ | Module Mismatch | See your authorized Pride Provider. |

NOTE: You must power the controller off and then on again to reset the controller, even if the source of the fault is removed/corrected.

In the event of a fault, the system status light displays diagnostic indications. Faults are encoded as follows: one (for a low battery voltage fault) to twelve (module mismatch) and are displayed by the light flashing the number of times prescribed by the fault code. The flash sequence (one to twelve) is followed by a long off period (2 seconds). If more than one fault exists, then the fault having the highest priority is indicated. The controller must be turned off and then on again even if the source of the fault is removed. If you cannot resolve the problem, contact your authorized Pride Provider.

IX. CARE AND MAINTENANCE

CARE AND MAINTENANCE

Your Jazzy is a sophisticated power chair. Like any motorized vehicle, it requires routine maintenance checks. You can perform some of these checks, but others require assistance from an authorized Pride Provider. Preventive maintenance is very important. If you follow the maintenance checks in this section as scheduled, you can help ensure that your Jazzy gives you years of trouble-free operation. If you have any doubt as to your Jazzy's care or operation, contact your authorized Pride Provider.

Your Jazzy, like most electrical equipment, is susceptible to damage from the elements. Avoid damp areas of any kind.



CAUTION! Direct exposure to water or dampness could cause the power chair to malfunction electronically and mechanically. Water can cause electrical components to corrode and the chair's frame to rust.

Should your Jazzy come in contact with water:

1. Dry your Jazzy as thoroughly as possible with a towel.
2. Allow your Jazzy to sit in a warm, dry place for 12 hours to allow unseen water to evaporate.
3. Check the joystick operation and the brakes before using your Jazzy again.
4. If any inconsistencies are found, take your Jazzy to an authorized Pride Provider.

Temperature

Some of the parts of your Jazzy are susceptible to extreme changes in temperature. Always keep your Jazzy between the temperatures of 18° F and 122° F.

- In extremely cold temperatures the batteries may freeze. The specific temperature at which they freeze depends on a number of factors, such as battery charge, usage, and composition of the batteries (e.g., AGM or Gel-Cell).
- Temperatures above 122° F may cause your Jazzy to operate at a reduced speed. This reduced speed is a safety feature built into the controller that helps prevent damage to the motor and other electrical components. See VIII. "Operation."

General Guidelines

- Avoid knocking or bumping the controller, especially the joystick.
- Avoid prolonged exposure of your Jazzy to extreme conditions, such as heat, cold, or moisture.
- Keep the controller clean.
- Check all connectors on the electronics tray to ensure that they are all tight and secured properly.
- When the battery condition meter is completely lit, the batteries are fully charged, and the controller and the electrical system are OK.
- If one red light on the battery condition meter is blinking slowly, the batteries are low and need to be charged, but the controller and the electrical system are OK.
- If the battery condition meter is blinking rapidly, the controller has detected a fault in either its own circuits or in your Jazzy's circuits. See VIII. "Operation."
- Make sure the drive tires are inflated to **30 – 35 psi**.



WARNING! Overinflating tires can cause them to explode and can result in personal injury.

WARNING! Do not use a high pressure hose to inflate your tires.

IX. CARE AND MAINTENANCE

- Use a rubber conditioner on the tire sidewalls to help preserve them.



WARNING! Never use a rubber conditioner on the tread area of the tires; doing so may make the tires slippery and cause your Jazzy to skid.

- The body shroud has been sprayed with a clear sealant coating. You can apply a light coat of car wax to help it retain its high-gloss appearance.
- Check all electrical connections. Make sure they are tight and are not corroded. Batteries must sit flat within the battery well, with the battery terminals facing inward, toward each other. Refer to the frame decal for the correct wiring layout. See figure 28.
- All wheel bearings are prelubricated and sealed. They require no subsequent lubrication.

Daily Checks

- With the controller turned off, check the joystick. Make sure it is not bent or damaged and that it returns to the neutral position when you release it. Check the rubber boot around the base of the joystick for damage. Visually inspect the boot. Do not handle or try to repair it. See your authorized Pride Provider if there is a problem.
- Visually inspect the controller harness. Make sure that it is not frayed, cut, or has any wires exposed. See your authorized Pride Provider if there is a problem with any harnesses.

Weekly Checks

- Disconnect and inspect the controller from the electronics tray. Look for corrosion. Contact your authorized Pride Provider if necessary.
- Ensure that all parts of the controller system are securely fastened to your power chair. Do not overtighten any screws.
- Check for proper tire inflation. There should be **30 – 35 psi** in each tire. If a tire does not hold air, see an authorized Pride Provider for replacement of the tube.
- Calibrate the joystick if a noticeable difference in performance is detected or if the joystick does not operate properly. To calibrate the joystick, power off the unit, place the joystick in the neutral position, and power the unit back on. If a problem still exists with your joystick's performance, contact your authorized Pride Provider.
- Check the brakes. This test should be carried out on a level surface with at least three feet of clearance around your power chair.

To check the brakes:

1. Turn on the controller and turn down the speed level of your power chair.
2. After one second, check the battery condition meter. Make sure that it remains on.
3. Slowly push the joystick forward until you hear the electric brakes click. Immediately release the joystick. You must be able to hear each electrical brake operating within a few seconds of joystick movement. Repeat this test three times, pushing the joystick backwards, then left, and then right.

To calibrate the joystick (Remote Plus only):

1. Position the joystick in the full reverse position and hold it there. Turn on the controller.
2. The battery condition meter lights up from one light to ten lights, and then back to one light. It does this twice, then blinks rapidly.
3. Turn off the controller.
4. Position the joystick in the full forward position and hold it there; then turn the controller on.
5. The battery condition meter lights up from one light to ten lights, and then back to one light. It does this twice, then blinks once, and then it blinks continuously.
6. Turn off the controller. Now the joystick and controller are set up to function properly together.

IX. CARE AND MAINTENANCE

Monthly Checks

- Check that the anti-tip wheels do not rub the ground when you operate the Jazzy. Adjust them as necessary. See VI. “Comfort Adjustments.”
- Check for extreme wear on the anti-tip wheels. Replace them as necessary.
- Check for drive tire wear. See an authorized Pride Provider for repair.
- Check the rear casters for wear. Replace them as necessary.
- Check the rear forks for damage or fluttering which indicates that they may need to be adjusted or have the bearings replaced. See an authorized Pride Provider for repair.
- Keep your Jazzy clean and free of foreign material, such as mud, dirt, hair, food, drink, etc.

Yearly Checks

Take your Jazzy to an authorized Pride Provider for yearly maintenance. This helps ensure that your Jazzy is functioning properly and helps prevent future complications.

Storage

Your power chair should be stored in a dry place, free from temperature extremes. When storing, disconnect the batteries from the Jazzy. See VII. “Batteries and Charging.”



WARNING! If you fail to store the unit properly, the frame can rust and the electronics can be damaged.

Cleaning Instructions



CAUTION! Never hose off your Jazzy or place it in direct contact with water. Your Jazzy has a painted, ABS plastic body shroud that allows it to be easily wiped clean with a damp cloth.

CAUTION! Never use any chemicals to clean a vinyl seat, as they may cause the seat to become slippery or dry out and crack. Use soapy water and dry the seat thoroughly.

Tire/Wheel Replacement

If you have pneumatic tires and you have a flat tire, replace the tube. If your chair is equipped with a solid tire insert, then you must replace the whole wheel assembly. Replacement tires, tubes, and wheel assemblies are readily available through your authorized Pride Provider.



WARNING! To avoid possible injury, be sure that the controller's power is turned off and the power chair is not in freewheel mode before performing this procedure.

WARNING! Completely deflate the tire before attempting repair.

Follow these easy steps for a quick and safe repair for both solid and pneumatic tires:

1. Turn off the power to the controller.
2. Set the power chair up on blocks.
3. If you are changing a pneumatic tire, completely deflate it before removing the wheel.
4. Use a socket wrench to remove the drive wheel nut from the center hub of the wheel.
5. Pull the wheel off the axle.

IX. CARE AND MAINTENANCE

6. Remove the old tube from the pneumatic tire and replace it with a new tube.
7. Slide the wheel back onto the shaft.
8. Reinstall the drive wheel nut into the center hub and tighten.
9. Inflate the pneumatic tire to **30 - 35 psi**.
10. Remove the power chair from the blocks.

Battery Replacement

A diagram is printed on a decal located on the Jazzy frame near the battery tray. See figure 27.



WARNING! Battery posts, terminals, and related accessories contain lead and lead compounds. Wear goggles and gloves when handling batteries and wash hands after handling.

WARNING! Pride Power Chair batteries are heavy. See specifications table. If you are unable to lift that much weight, be sure to get help. Lifting beyond your capacity can result in personal injury.

To replace the batteries:

1. Turn the power off.
2. Make sure that the Jazzy is in drive mode. See IV. "The Jazzy 1101/1121."
3. Remove the ball detent pin that secures the footrest to the frame. See figure 12.
4. Lift off the footrest.
5. Locate the battery quick disconnects on the frame and disconnect both of them. See figure 27.
6. Remove the batteries from the power base.
7. Disconnect the wiring harness from each battery.
8. Reinstall the wiring harnesses on each battery. Make sure that you connect the red wire to the positive (+) battery terminal and the black wire to the negative (-) battery terminal. See figure 27.



WARNING! Make sure you tighten the fasteners so that the connections are secure.

9. Place the batteries back into the power base.

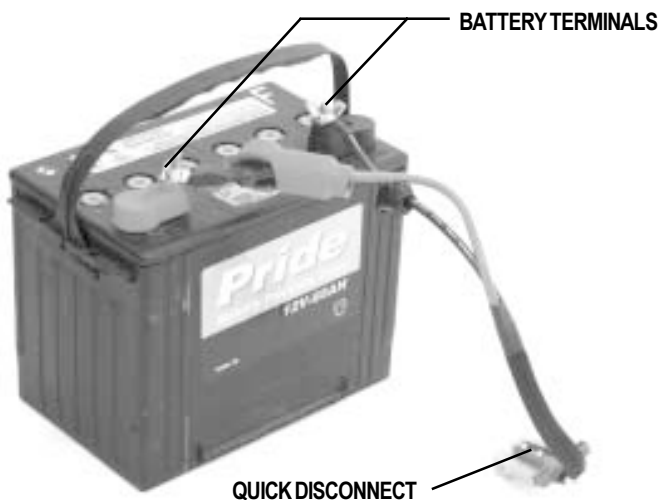

Figure 27. Battery and Harness



Figure 28. 1101/1121 Battery Wiring Diagram Label

IX. CARE AND MAINTENANCE

10. Connect the battery quick disconnects according to the battery wiring diagram label. See figure 28.
11. Reinstall the footrest.

Motor Brushes

The electric motors that power your Jazzy use carbon brushes. These brushes may become susceptible to wear over a long period of time. The motor brushes are the two contacts located inside the motor assembly that supply power to the motor. They are designed to provide several thousand hours of operation. However, if the brushes become dirty with carbon deposits or wear out, the motor will run poorly or not at all.

To inspect or replace the motor brushes:

1. Remove the seat and body shroud.
2. Disconnect the batteries.
3. Unscrew the motor brush caps. See figure 29.
4. Remove the brushes.
5. Inspect for wear. See figure 30.
6. Replace brushes, if necessary. Contact your authorized Pride Provider for replacement brushes.



CAUTION! If an inspection determines excessive wear on the brushes, they must be replaced or motor damage will result. Failure to maintain the brushes could void your Jazzy's warranty.

When to See Your Authorized Pride Provider for Service

The following symptoms could indicate a serious problem with your Jazzy. If necessary, contact your authorized Pride Provider. When calling, have the model number, serial number, nature of the problem, and the trouble code if available.

- Motor noise
- Frayed harnesses
- Cracked or broken connectors
- Uneven wear on any of the tires
- Jerky motion
- Pulling to one side
- Bent or broken wheel assemblies
- Does not power up
- Powers up, but does not move

Corrective Maintenance

If the battery condition meter does not light up when you turn on the power:

- Check the harness connections. Make sure they are tight.
- Check the circuit breaker. Reset it if necessary.
- Check the battery connections.

If the above conditions prove normal, you can load test the batteries with a battery load tester. These testers are available at automotive parts stores. Disconnect both batteries before load testing and follow the directions that come with the load tester. If either one of the batteries fails the load test, replace both of them. If your Jazzy still does not power up, contact your authorized Pride Provider.

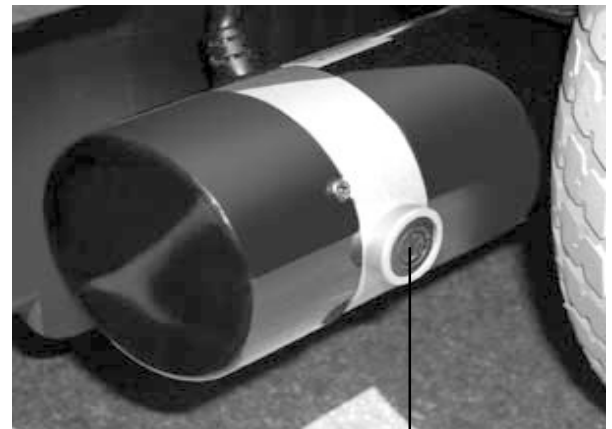

Figure 29. Motor

MOTOR BRUSH CAP

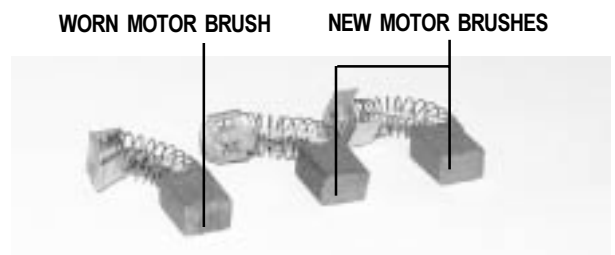

Figure 30. Motor Brushes

X. OPTIONAL ACCESSORIES

OPTIONAL ACCESSORIES

The following accessories are available from your authorized Pride Provider.

Positioning Belt

The positioning belt is designed to support your torso so that you do not slide down or forward in the seat.

- The positioning belt is not designed for use as a restraining device.
- Make sure the belt is secure but does not cause discomfort.



WARNING! The positioning belt is not designed for use as a seat belt in a motor vehicle. Nor is your Jazzy suitable for use as a seat in any vehicle. Anyone traveling in a vehicle should be properly belted into seats approved by the vehicle manufacturer.

Cane and Crutch Holder

The removable cane and crutch holder is mounted to the back of the seat by means of the accessory bracket.

Walker Holder

The removable walker holder is mounted to the back of the seat by means of the accessory bracket. It can hold a standard size walker.

Cup Holder

The cup holder is mounted to the armrest.

Oxygen Tank Holder

The removable oxygen tank holder is mounted to the back of the seat by means of the accessory bracket.

Rear Basket

The rear basket is mounted to the accessory bracket. It has a handle that you can use when you remove the basket.

Swing-Away Joystick Bracket

This option enables you to move the joystick from the front of the armrest to the side of the armrest without disconnecting it.

Dust Cover

These sturdy canvas covers help protect your Jazzy when not in use.

XI. WARRANTY

Lifetime Limited Warranty

For the lifetime of your Jazzy from the date of purchase, Pride will repair or replace at our option, to the original purchaser, free of charge, any of the following parts found upon examination by an authorized representative of Pride to be defective in material and/or workmanship:

- Structural frame components

Two-Year Warranty

For two (2) years from the date of purchase, Pride will repair or replace at our option, to the original purchaser, free of charge, any of the following parts found upon examination by an authorized representative of Pride to be defective in material and/or workmanship:

- Electronics

Eighteen-Month Warranty

For eighteen (18) months from the date of purchase, Pride will repair or replace, at our option to the original purchaser, free of charge, any of the following parts found upon examination by an authorized representative of Pride to be defective in material and/or workmanship:

- Motor/gearbox assembly

Warranty Exceptions

Motor: If damage occurs to the commutator of a motor as a result of not replacing the motor brushes after heavy wear to the brushes. Motor brushes are wear items and are not warranted.

Brake: One (1) year warranty for the electrical function of the brake. Brake pads are a wear item and are not warranted.

Six-Month Limited Warranty

For six (6) months from date of purchase, Pride will repair or replace, at our option, to the original purchaser, free of charge, any of the following parts found upon examination by an authorized representative of Pride to be defective in material and/or workmanship:

- Plastic components, except body
- Bearings and bushings
- Rubber components (except tires and tubes)
- Casters and anti-tip wheels

Battery warranty is covered by the battery manufacturer. Battery warranty is not covered by Pride.

Warranty service can be performed by an authorized Pride Provider or by Pride. Do not return faulty parts to Pride without prior consent. All transportation costs and shipping damage incurred while submitting parts for repair or replacement are the responsibility of the original purchaser.

Warranty Exclusions

- ABS plastic body shrouds and footrest covers (wear items)
 - Batteries (battery manufacturer provides a six-month limited warranty)
 - Tires and tubes
 - Upholstery and seating
 - Repairs and/or modifications made to any part without specific consent from Pride
 - Circumstances beyond the control of Pride
 - Labor, service calls, shipping, and other charges incurred for repair of the product, unless specifically authorized by Pride
- Mobility Products Corporation

Damage caused by:

- Battery fluid spillage or leakage
- Improper operation, maintenance, or storage
- Abuse, misuse, accident, or negligence
- Commercial use or use other than normal

There is no other express warranty.

Implied warranties, including those of merchantability and fitness for a particular purpose, are limited to one (1) year from the date of purchase and to the extent permitted by law. Any and all implied warranties are excluded. This is the exclusive remedy. Liabilities for consequential damages under any and all warranties are excluded.

Some states do not allow limitations on how long an implied warranty lasts or do not allow the exclusion of limitation of incidental or consequential damages, so the above limitation or exclusion may not apply to you.

This warranty gives you specific rights, and you may also have other rights which vary from state to state.

Please fill out and return the warranty card to Pride. This assists Pride in providing the best possible technical and customer service.

NOTES

Jazzy Power Chairs®

How a Power Chair Should Feel™



Quality Control- 1101/1121

Thank you for making the Pride Jazzy your choice in power chairs.

We have thoroughly inspected your Jazzy. The following checkmarks indicate that it has been test driven and inspected.

Model # _____

Serial # _____

Inclusion of all Parts

Controller

_____ **Controller Serial #**

_____ **Joystick Serial #**

Performance

Fit and Finish



Pride keeps a more detailed report on file at the factory.

Date Inspected

Inspector